

Additional Science A

Twenty First Century Science Suite

OCR GCSE in Additional Science J631

Foreword to the Second Edition

This Second Edition of the OCR GCSE Additional Science A specification has been produced to correct minor errors found in the original edition (published in Dec 2005). There are no changes to actual content or the scheme of assessment. Centres should note however the grade descriptions in Appendix A have now been replaced with the correct versions.

Contents

1	About this Qualification	4
1.1	About the Twenty First Century Science Suite	4
1.2	About this Additional Science Specification	4
1.3	Qualification Titles and Levels	5
1.4	Aims	6
1.5	Prior Learning/Attainment	6
2	Summary of Content	7
3	Content	8
	Layout of Module Content	8
	Module B4: Homeostasis – Overview	9
	Module C4: Chemical Patterns – Overview	14
	Module P4: Explaining Motion – Overview	19
	Module B5: Growth and Development – Overview	24
	Module C5: Chemicals of the Natural Environment – Overview	27
	Module P5: Electric Circuits – Overview	33
	Module B6: Brain and Mind – Overview	39
	Module C6: Chemical Synthesis – Overview	44
	Module P6: The Wave Model of Radiation – Overview	48
4	Scheme of Assessment	53
4.1	Units of Assessment	53
4.2	Unit Options	54
4.3	Tiers	54
4.4	Assessment Availability	54
4.5	Assessment Objectives	55
4.6	Quality of Written Communication	56
5	Skills Assessment	57
5.1	Nature of Skills Assessment	57
5.2	Marking Internally Assessed Work	58
5.3	Regulations for Internally Assessed Work	65
6	Technical Information	67
6.1	Making Unit Entries	67
6.2	Making Qualification Entries	67
6.3	Grading	68
6.4	Result Enquiries and Appeals	69
6.5	Shelf-Life of Units	69
6.6	Unit and Qualification Re-sits	69
6.7	Guided Learning Hours	69
6.8	Code of Practice/Subject Criteria/Common Criteria Requirements	69
6.9	Arrangements for Candidates with Particular Requirements	70
6.10	Prohibited Qualifications and Classification Code	70

7	Other Specification Issues	71
7.1	Overlap with other Qualifications	71
7.2	Progression from these Qualifications	71
7.3	ICT	71
7.4	Citizenship	72
7.5	Key Skills	72
7.6	Spiritual, Moral, Ethical, Social, Legislative, Economic and Cultural Issues	73
7.7	Sustainable Development, Health and Safety Considerations and European Developments	73
7.8	Avoidance of Bias	74
7.9	Language	75
7.10	Support and Resources	75
<hr/>		
	Appendix A: Grade Descriptions	76
	Appendix B: Requirements Relating to Mathematics	78
	Appendix C: Physical Quantities and Units	79
	Appendix D: Health and Safety	80
	Appendix E: Explanation of Terms Used in Module Content	81
	Appendix F: Electrical Symbols	82
	Appendix G: Periodic Table	83

1 About this Qualification

1.1 About the Twenty First Century Science Suite

The Twenty First Century Science suite comprises six specifications which share common material, use a similar style of examination questions and have a common approach to skills assessment. The qualifications available as part of this suite are:

GCSE Science A (J630) which emphasises scientific literacy – the knowledge and understanding which candidates need to engage, as informed citizens, with science-based issues. As with other courses in the suite, this qualification uses contemporary, relevant contexts of interest to candidates, which can be approached through a range of teaching and learning approaches.

GCSE Additional Science A (J631) which is a concept-led course developed to meet the needs of candidates seeking a deeper understanding of basic scientific ideas. The course focuses on scientific explanations and models, and gives candidates an insight into how scientists develop scientific understanding of ourselves and the world we inhabit.

GCSE Additional Applied Science A (J632) which meets the needs of candidates who wish to develop their scientific understanding through authentic, work related contexts. The course focuses on procedural and technical knowledge that underpins the work of practitioners of science and gives candidates an insight into what is involved in being a practitioner of science.

GCSE Biology A (J633)
GCSE Chemistry A (J634)
GCSE Physics A (J635) each of which provides an opportunity for further developing an understanding of science explanations, how science works and the study of elements of applied science, with particular relevance to professional scientists.

This suite is supported by the Nuffield Curriculum Centre and The University of York Science Education Group.

1.2 About this Additional Science Specification

This booklet contains OCR's GCSE specification in Additional Science for teaching from September 2006 and first certification in June 2008.

This specification, together with GCSE Science A (J630), aims to provide candidates with the scientific understanding needed to progress to further studies of science, should they choose to undertake them. Candidates should gain a deeper understanding of:

- scientific explanations and models;
- how these concepts can be applied to the benefit of humanity;
- how scientists help to develop our understanding of ourselves and the world we inhabit.

This specification comprises nine teaching modules which are assessed through five units.

Unit	Unit Code	Title	Duration	Weighting	Total Mark
1	A215	Additional Science A Unit 1 – modules B4, C4, P4	40 mins	16.7%	42
2	A216	Additional Science A Unit 2 – modules B5, C5, P5	40 mins	16.7%	42
3	A217	Additional Science A Unit 3 – modules B6, C6, P6	40 mins	16.7%	42
4	A218	Additional Science A Unit 4 – Ideas in Context	45 mins	16.7%	40
5	A220	Additional Science A Unit 5 – Practical Investigation	-	33.3%	40

Candidates take all five units. Alternatively, candidates can also achieve GCSE Additional Science A by taking Unit 2 from each of Biology (A222), Chemistry (A322) and Physics (A332) plus Units 4 and 5 from this specification.

1.3 Qualification Titles and Levels

This qualification is shown on a certificate as OCR GCSE in Additional Science.

This qualification is approved by the regulatory authority, QCA, as part of the National Qualifications Framework.

Candidates who gain grades G to D will have achieved an award at Foundation Level (Level 1 of the National Qualifications Framework).

Candidates who gain grades C to A* will have achieved an award at Intermediate Level (Level 2 of the National Qualifications Framework).

1.4 Aims

The aims of this GCSE specification are to encourage candidates to:

- acquire a systematic body of scientific knowledge, and the skills needed to apply this in new and changing situations in a range of domestic, industrial and environmental contexts;
- acquire an understanding of scientific ideas, how they develop, the factors which may affect their development and their power and limitations;
- plan and carry out investigative tasks, considering and evaluating critically their own data and that obtained from other sources, and using ICT where appropriate;
- use electronic (internet, CD ROMs, databases, simulations etc.) and/or more traditional sources or information (books, magazines, leaflets etc.) to research and plan an investigation.
- select, organise and present information clearly and logically, using appropriate scientific terms and conventions, and using ICT where appropriate;
- interpret and evaluate scientific data from a variety of sources.

1.5 Prior Learning/Attainment

Candidates who are taking courses leading to this qualification at Key Stage 4 should normally have followed the corresponding Key Stage 3 programme of study within the National Curriculum.

Other candidates entering this course should have achieved a general educational level equivalent to National Curriculum Level 3.

2 Summary of Content

The specification content is displayed as nine modules outlined below. A module defines the required teaching and learning outcomes.

Module B4: Homeostasis

- What is homeostasis?
- Why is homeostasis important for a cell?
- How is our body temperature kept constant?
- How does the body control water balance?

Module C4: Chemical Patterns

- What are the patterns in the properties of elements?
- How do chemists explain the patterns in the properties of the elements?
- How do chemists explain the properties of compounds of Group 1 and Group 7 elements?

Module P4: Explaining Motion

- How can we describe motion?
- What are forces?
- What is the connection between forces and motion?
- How can we describe motion in terms of energy changes?

Module B5: Growth and Development

- How does an organism produce new cells?
- How do genes control growth and development within the cell?
- How do new organisms develop from a single cell?

Module C5: Chemicals of the Natural Environment

- What types of chemicals make up the atmosphere and hydrosphere?
- What types of chemicals make up the Earth's lithosphere?
- Which chemicals make up the biosphere?
- How can we extract useful metals from minerals?

Module P5: Electric Circuits

- Electric current – a flow of what?
- What determines the size of the current in an electric circuit?
- How do parallel and series circuits work?
- How is mains electricity produced?
- How much electrical energy do we use at home?

Module B6: Brain and Mind

- How do organisms respond to changes in their environment?
- How is information passed through the nervous system?
- What are reflex actions?
- How do humans develop more complex behaviour?
- What do we know about the way in which the brain co-ordinates our senses?
- How do drugs affect our nervous systems?

Module C6: Chemical Synthesis

- Chemicals and why we need them.
- Planning, carrying out and controlling chemical synthesis

Module P6: The Wave Model of Radiation

- What are waves?
- Why do scientists think that light and sound are waves?
- Do all types of electromagnetic radiation behave in the same way?
- How is information added to a wave?

3 Content

Layout of Module Content

The content is displayed as nine modules B4, B5, B6, C4, C5, C6, P4, P5 and P6. Each module has an overview page summarising the content. Each module is divided into between 3 and 6 topics.

Some symbols and fonts are provided to give teachers additional information, expressed in abbreviated form, about the way in which the content is linked to other parts of the specification, and the table below summarises this information.

Abbreviation	Explanation and guidance
Bold	These content statements will only be assessed on Higher Tier papers.
①	Advisory notes for teachers to clarify depth of cover required.

MODULE B4: HOMEOSTASIS – OVERVIEW

Extreme environments hold a fascination for human beings, and people continue to push their bodies to the furthest limits of endurance. For some individuals, e.g. premature babies or patients with kidney disease, their homeostatic mechanisms must be artificially supported. These contemporary topics provide engaging contexts for the coherent study of homeostasis.

This module looks at the importance of homeostasis for individual cells and whole organisms and the effects of disrupting homeostasis. A general understanding of homeostasis is developed in the first topic, through an analogy with control mechanisms in artificial systems. This understanding is applied at cell level in the second topic, which focuses on movement of molecules in and out of cells, and enzyme function. The remaining two topics look in detail at temperature control and water balance in the whole organism.

Topics

B4.1 What is homeostasis?

Modelling of homeostasis mechanisms by an artificial system. Principle of negative feedback.

B4.2 Why is homeostasis important for a cell?

Transport into and out of cells.
Enzyme function.

B4.3 How is our body temperature kept constant?

Detection of temperature change;
Co-ordination by the brain;
Responses to fall or rise in body temperature.

B4.4 How does the body control water balance?

Kidney function for excretion and water balance.

ICT Opportunities

This module offers opportunities for illustrating the use of ICT in science, for example:

- modelling control systems which involve negative feedback;
- molecular modelling to develop explanations of enzyme action.

Use of ICT in teaching and learning can include:

- animation to explain enzyme action and the effect of temperature on enzyme activity;
- a data logger to monitor body temperature over 12 or 24 hours;
- animation to explore kidney function;
- the internet to research symptoms and treatments of hypothermia and heatstroke.

MODULE B4: HOMEOSTASIS

B4.1 What is homeostasis?

1. recall that homeostasis is the maintenance of a constant internal environment;
2. understand that automatic control systems throughout the body maintain a range of factors at steady levels, which are required for cells to function properly (limited to temperature and water);
3. understand that strenuous exercise, survival in hot or cold climates: **scuba-diving** and **mountain climbing** affect homeostasis (temperature, **blood oxygen levels**, hydration and **salt levels**);
4. understand how artificial systems, such as the temperature control system in an incubator, are similar to body control systems;
5. understand that artificial and body systems have:
 - receptors to detect stimuli;
 - processing centres to receive information and coordinate responses;
 - effectors which produce the response automatically;
6. **understand the principle of negative feedback;**
7. **recall that negative feedback between the effector and the receptor of a control system reverses any changes to the systems steady state;**
8. **understand that some effectors work antagonistically, which allows a more sensitive response.**

MODULE B4: HOMEOSTASIS

B4.2 Why is homeostasis important for a cell?

1. understand that diffusion is the passive overall movement of molecules from a region of their high concentration to a region of their low concentration;
2. understand that osmosis (a specific case of diffusion) is the overall movement of water from a dilute to a more concentrated solution through a partially permeable membrane;
3. recall some examples of chemicals, such as O_2 , CO_2 and dissolved food, which move in/out of cells by diffusion;
4. **understand that some chemicals (for example, glucose) are also moved by active transport;**
5. **understand that if excess water moves into animal cells by osmosis the cell membrane may rupture and if too much water moves out of cells they are unable to function correctly;**
6. recall that enzymes are proteins that speed up chemical reactions in cells;
7. recall that enzymes need a specific constant temperature to work at their optimum;
8. explain how, at low temperatures, small increases in temperature increase the frequency and energy of collisions between an enzyme and other molecules, so the rate of reaction increases;
9. recall that at higher temperatures enzymes stop working (denature);
10. understand that only molecules with the correct shape can fit into the enzyme. This is known as the 'lock and key' model;
11. **recall that enzymes have a small part called the active site where certain molecules bind to the enzyme and the reaction occurs;**
12. **understand that the shape of the active site is can be changed by heating above a certain temperature and altering the pH, so that the molecules can no longer fit and the reaction cannot happen.**

MODULE B4: HOMEOSTASIS

B4.3 How is our body temperature kept constant?

1. recall that energy gain and loss must be balanced in order to maintain a constant body temperature;
2. recall that body extremities tend to be cooler than the core body temperature, and that energy is transferred from the blood to the tissues when blood reaches cooler parts;
3. recall that temperature receptors in the skin detect external temperature;
4. recall that temperature receptors in the brain (**hypothalamus**) detect the temperature of the blood;
5. understand that the brain (**hypothalamus**) acts as a processing centre, receiving information from the temperature receptors, and triggering the effectors automatically;
6. recall that effectors include sweat glands and muscles;
7. understand that at high body temperatures:
 - more sweat is produced by sweat glands which cools the body when it evaporates;
 - **blood vessels supplying the capillaries of the skin dilate (vasodilation) allowing more blood to flow through skin capillaries which increases energy loss;**
8. recall that heat stroke is an uncontrolled increase in body temperature;
9. recall the common causes, symptoms and initial treatment of heat stroke;
10. explain how exposure to very hot temperatures produces increased sweating, and can produce dehydration, which may lead to reduced sweating and further increase of core body temperature;
11. understand that when core body temperature becomes too high the normal mechanisms for controlling body temperature break down;
12. understand that at low body temperatures:
 - the increased rate of respiration stimulated when muscles contract rapidly (shivering) results in some of the energy transferred in respiration warming the surrounding tissues;
 - **blood vessels supplying the capillaries of the skin constrict (vasoconstriction) restricting blood flow through skin capillaries which reduces energy loss;**
13. recall that hypothermia is when core body temperature falls below 35°C;
14. recall the cause, symptoms and initial treatment of hypothermia;
15. understand that in hypothermia body heat cannot be replaced as fast as it is being lost.

MODULE B4: HOMEOSTASIS

B4.4 How does the body control water balance?

1. recall that water is gained from drinks, food and respiration and is lost through sweating, breathing, faeces and the excretion of urine;
2. understand that a balanced water level is important for maintaining the concentration of cell contents at the correct level for cell activity;
3. describe how the kidneys play a vital role in removing waste urea from the blood and in balancing levels of other chemicals in the blood by:
 - filtering small molecules from the blood to form urine (water, salt and urea);
 - reabsorbing all the sugar;
 - reabsorbing as much salt as the body requires;
 - reabsorbing as much water as the body requires;
 - excreting the remaining urine, which is stored in the bladder;
- ① Candidates are not expected to recall details of kidney structure.
4. understand that the kidneys balance water levels by producing dilute or concentrated urine as a response to concentration of blood plasma, which varies with external temperature, exercise level, intake of fluids and salt;
5. **recall that concentration of urine is controlled by a hormone called ADH, which is released into the bloodstream by the pituitary gland;**
6. **understand how ADH secretion is controlled by negative feedback;**
7. understand that alcohol results in a greater volume of more dilute urine, **due to ADH suppression**, which can lead to dehydration;
8. understand that the drug Ecstasy results in a smaller volume of less dilute urine, **due to increased ADH production**.

MODULE C4: CHEMICAL PATTERNS – OVERVIEW

This module features a central theme of modern chemistry. It shows how theories of atomic structure can be used to explain the properties of elements and their compounds. The module also includes examples to show how spectra and spectroscopy have contributed to the development of chemical knowledge and techniques. This module shows how atomic structure can be used to help explain the behaviour of elements.

The first topic looks at the Periodic Table and patterns that exist within it, focusing on Group 1 and Group 7. This topic also introduces the use of symbols and equations as a means of describing a chemical reaction. An explanation of the patterns is then developed in the next topic by linking atomic structure with chemical properties.

The third, and final, topic takes this further by introducing ions and showing how ionic theory can account for properties of compounds of Group 1 with Group 7 elements.

Topics

C4.1 What are the patterns in the properties of elements?

Classifying elements by their position in the Periodic Table;
patterns in Group 1; patterns in Group 7;
using symbols and equations to represent chemical reactions

C4.2 How do chemists explain the patterns in the properties of elements?

Flame tests and spectra and their use for identifying elements and studying atomic structure. Classifying elements by their atomic structure; linking atomic structure to chemical properties.

C4.3 How do chemists explain the properties of compounds of Group 1 and Group 7 elements?

Ions; linking ion formation to atomic structure;
properties of ionic compounds of alkali metals and halogens.

ICT Opportunities

This module offers opportunities for illustrating the use of ICT in science, for example:

- storing large sets of data;
- selecting and presenting data in a variety of forms to explore patterns and trends.

Use of ICT in teaching and learning can include:

- an interactive periodic table to explore similarities and differences between elements;
- a spreadsheet to display patterns in chemical data;
- video clips to test predictions about the reactions of elements such as caesium and fluorine;
- the internet to research the uses of alkali metals or halogens and their compounds.

MODULE C4: CHEMICAL PATTERNS

C4.1 What are the patterns in the properties of elements?

1. recall that atoms of each element have different proton numbers;
2. understand that arranging the elements in order of their proton numbers gives repeating patterns in the properties of elements;
3. be able to use the Periodic Table to obtain the names, symbols, relative atomic masses and proton numbers of elements;
4. recall that a group of elements is a vertical column in the Periodic Table and that the elements have similar properties;
5. recall that a period is a row of elements in the Periodic Table;
6. be able to use the Periodic Table to classify an element as a metal or non-metal;
7. be able to use patterns in the Periodic Table to interpret data and predict properties of elements;
- ① Candidates will be given a copy of the Periodic Table (as in Appendix G) with the examination paper.
8. recall and recognise the chemical symbols for the group 1 metals: lithium, sodium and potassium;
9. recall that the alkali metals tarnish rapidly in moist air but are shiny when freshly cut;
10. be able to use qualitative and quantitative data to identify patterns and make predictions about the properties of group 1 metals (for example melting point, boiling point, density, formulae of compounds and relative reactivity);
11. describe the reactions of lithium, sodium and potassium with cold water;
12. recall that alkali metals react with water to form hydrogen and an alkaline solution of a hydroxide with the formula MOH;
13. recall that alkali metals react vigorously with chlorine to form colourless, crystalline salts with the formula MCl;
14. understand and be able to give examples to show that the alkali metals become more reactive as the group is descended;

MODULE C4: CHEMICAL PATTERNS

C4.1 What are the patterns in the properties of elements?

- recall the main hazard symbols and be able to give the safety precautions for handling hazardous chemicals (limited to harmful, toxic, irritant, corrosive, oxidizing, highly flammable);
- explain the precautions necessary when working with group 1 metals and alkalis;
- recall and recognise the chemical symbols for the atoms and molecules of the group 7 elements: chlorine, bromine and iodine;
- recall the states of the halogens at room temperature and pressure;
- recall the colours of the halogens in their normal physical state at room temperature and as gases;
- recall that the halogens consist of diatomic molecules;
- recall that the halogens can bleach dyes and kill bacteria in water;
- be able to use qualitative and quantitative data to identify patterns and make predictions about the properties of the group 7 elements (for example melting point, boiling point, formulae of compounds and relative reactivity);
- recall and be able to give examples to show that the halogens become less reactive as the group is descended;
- explain the safety precautions necessary when working with the halogens;
- recall the formulae of:
 - hydrogen, water and halogen molecules;
 - the halides and hydroxides of group 1 metals;
- be able to balance unbalanced symbol equations;**
- be able to write balanced equations to describe the chemical reactions of group 1 metals with water and halogens;**
- recall and use state symbols: (s), (l), (g) and (aq) in equations.

MODULE C4: CHEMICAL PATTERNS

C4.2 How do chemists explain the patterns in the properties of the elements?

1. describe the structure of an atom in terms of protons and neutrons in a very small central nucleus with electrons arranged in shells around the nucleus;
2. recall the relative masses and charges of protons, neutrons and electrons;
3. recall that in any atom the number of electrons equals the number of protons;
4. recall that all the atoms of the same element have the same number of protons;
5. recall that the elements in the modern Periodic Table are arranged in order of proton number;
6. recall that some elements emit distinctive flame colours when heated (for example lithium, sodium and potassium);
7. understand that the light emitted from an element gives a characteristic line spectrum;
8. understand that the study of spectra has helped chemists to discover new elements;
9. understand that the discovery of some elements depended on the development of new practical techniques (for example spectroscopy);
10. be able to use simple conventions (for example 2.8.1 or dots in circles) to represent the electron arrangements in the atoms of the first 20 elements in the Periodic Table;
11. recall that a shell (or energy level) fills across a period;
12. **understand that the chemical properties of an element are determined by its electron arrangement, illustrated by the electron configurations of the atoms of elements in groups 1 and 7.**

MODULE C4: CHEMICAL PATTERNS

C4.3 How do chemists explain the properties of compounds of Group 1 and Group 7 elements?

1. recall that molten compounds of metals with non-metals conduct electricity and that this is evidence that they are made up of charged particles called ions;
2. recall that an ion is an atom (or group of atoms) that has gained or lost electrons and so has an overall charge;
3. account for the charge on the ions of group 1 and group 7 elements by comparing the number and arrangement of the electrons in the atoms and ions of these elements;
4. **work out the formulae of ionic compounds given the charges on the ions;**
5. **work out the charge on one ion given the formula of a salt and the charge on the other ion;**
6. recall that compounds of group 1 metals and group 7 elements are ionic;
7. understand that solid ionic compounds form crystals because the ions are arranged in a regular lattice;
8. describe what happens to the ions when an ionic crystal melts or dissolves in water;
9. **explain that ionic compounds conduct electricity when molten or when dissolved in water because the ions are charged and they are able to move around independently in the liquid.**

MODULE P4: EXPLAINING MOTION – OVERVIEW

Simple but counterintuitive concepts of forces and motion, developed by Galileo and Newton, can transform young people's insight into everyday phenomena. These ideas also underpin an enormous range of modern applications, including spacecraft, urban mass transit systems, sports equipments and exciting rides at theme parks.

This module starts by looking at how speed is measured and represented graphically and the idea of velocity (as distinct from speed).

The second topic introduces the idea of forces: identifying, describing and using forces to explain simple situations. This is further developed in the third topic where resultant forces and changes in momentum are described.

The fourth and final topic considers the idea of work done by a force, gravitational potential energy and kinetic energy.

Topics

P4.1 How can we describe motion?

Calculation of speed; velocity; graphical representations of speed and velocity.

P4.2 What are forces?

The identification of forces and 'partner' forces.

P4.3 What is the connection between forces and motion?

Resultant forces and change in momentum; relating momentum to road safety measures.

P4.4 How can we describe motion in terms of energy changes?

Work done; changes in energy; GPE; KE; losses due to air resistance and friction.

ICT Opportunities

This module offers opportunities for illustrating the use of ICT in science, for example:

- computer programs that control the motion of spacecraft;
- use of computers for collecting, storing and displaying data on forces in simulated vehicle collisions;
- computer-enhanced use of radar to predict flight paths of aircraft.

Use of ICT in teaching and learning can include:

- video clips to provide contexts for learning about forces and motion;
- animation to illustrate interactive force pairs in various situations;
- animation to show the meaning of distance-time and other graphs;
- sensors and data loggers to collect measurements of movement for analysis;
- modelling software to analyse motion.

MODULE P4: EXPLAINING MOTION

P4.1 How can we describe motion?

1. apply the following equation to situations where an average speed is involved:

$$\text{speed (m/s)} = \frac{\text{distance travelled (m)}}{\text{time taken (s)}}$$

- ① Candidates should be able to apply the above equation to situations where an average speed is involved.
2. distinguish between average speed and instantaneous speed (in effect, an average over a short time interval) for examples of motion where speed is changing;
3. understand that distances measured in one direction are positive, and in the other, negative;
- ① Candidates are not expected to recall or use the term 'displacement'.
4. draw and interpret the shape of a distance-time graph for an object that is:
 - stationary;
 - moving at constant speed;
 - **moving with increasing or decreasing speed;**
5. interpret a steeper gradient of a distance-time graph as a higher speed;
- 6. calculate a speed from the gradient of a straight section of a distance-time graph;**
7. recall that the velocity of an object at any instant is its speed plus an indication of the direction;
8. understand that the velocity of an object moving in a straight line is positive if it is moving in one direction and negative if it is moving in the opposite direction;
9. draw and interpret the shape of a velocity-time graph for an object that is:
 - stationary;
 - moving in a straight line with constant speed;
 - moving in a straight line with steadily increasing or decreasing speed;
10. relate these ideas about recording motion to applications such as lorry tachographs.

MODULE P4: EXPLAINING MOTION

P4.2 What are forces?

1. recall that a force arises from an interaction between two objects;
2. understand that when one object exerts a force on another, it always experiences a force in return;
3. in simple everyday situations
 - identify forces arising from an interaction between two objects;
 - identify the 'partner' of a given force (i.e. the other force of the interaction pair);
 - specify, for each force, the object which exerts it, and the object on which it acts;
 - use arrows to show the sizes and directions of forces acting;
4. understand that the two forces in an interaction pair are equal in size and opposite in direction; and that they act on different objects;
5. recall that some forces (for example friction, reaction of a surface) arise in response to the action of an applied force;
6. describe the interaction between an object and a surface it is resting on: the object pushes down on the surface; the surface pushes up on the object with an equal force; this is called the reaction of the surface;
7. describe the interaction between two surfaces which slide (or tend to slide) relative to each other: each surface experiences a force in the direction which prevents (or tends to prevent) relative movement; this interaction is called friction;
- ① Candidates should be able to apply these ideas to explain situations such as walking, or the driving force on vehicles.
8. be able to use the idea of a pair of equal and opposite forces to explain in outline how rockets and jet engines work.

MODULE P4: EXPLAINING MOTION

P4.3 What is the connection between forces and motion?

1. be able to interpret situations in which several forces act on an object;
2. recall that the resultant force on an object is the sum of all the individual forces acting on it, taking their directions into account;
3. recall that if a resultant force acts on an object, it causes a change of momentum in the direction of the force;
4. use the definition:
 - $\text{momentum} = \text{mass} \times \text{velocity}$
(kg m/s) (kg) (m/s);
5. understand that the size of the change of momentum is related to the size of the resultant force and the time for which it acts in the following way:
 - $\text{change of momentum} = \text{resultant force} \times \text{time for which it acts}$
(kg m/s) (N) (s)
6. understand how the horizontal motion of objects (like cars and bicycles) can be analysed in terms of a driving force (produced by the engine or the cyclist), and a counter force (due to friction and air resistance);
7. recall that for a moving object, if the driving force is:
 - greater than the counter force, the vehicle will speed up;
 - equal to the counter force, the vehicle will move at constant speed in a straight line;
 - smaller than the counter force, the vehicle will slow down;
8. understand that, in situations involving a change in momentum (such as a collision), the longer the duration of the impact, the smaller the average force for a given change in momentum;
9. use this idea to discuss and explain the action of road safety measures, such as car seat-belts, crumple zones, air bags, cycle and motorcycle helmets;
10. understand that, if the resultant force on an object is zero, its momentum does not change (if it is stationary, it stays at rest; if it is already moving, it continues at a steady speed in a straight line).

MODULE P4: EXPLAINING MOTION

P4.4 How can we describe motion in terms of energy changes?

1. recall that the energy of a moving object is called kinetic energy ;
2. recall that as an object falls, its gravitational potential energy decreases;
3. recall that when a force causes movement of an object, work is done;
4. use the equation:
 - $$\text{work done by a force} = \text{force} \times \text{distance moved by the force}$$

(joule, J) (newton, N) (metre, m)
5. understand that when work is done on an object, the energy of the object increases and when work is done by an object, the energy of the object decreases according to the relationship:
 - $$\text{change in energy} = \text{work done}$$

(joule, J) (joule, J)
6. understand that when an object is lifted to a higher position above the ground, work is done by the lifting force against the gravitational force acting on the object (its weight); this increases the object's gravitational potential energy (GPE);
7. use the equation:
 - $$\text{change in GPE} = \text{weight} \times \text{vertical height difference}$$

(joule, J) (newton, N) (metre, m)
8. understand that when a force acting on an object makes its velocity increase, the force does work on the object and this results in an increase in its kinetic energy;
9. understand that the greater the mass of an object and the faster it is moving, the more kinetic energy it has;
10. use the equation:
 - $$\text{kinetic energy} = \frac{1}{2} \times \text{mass} \times [\text{velocity}]^2$$

(joule, J) (kilogram, kg) (metre per second, m/s)²
11. explain that if friction and air resistance can be ignored, an object's kinetic energy increases by an amount equal to the work done on it by an applied force;
12. understand that air resistance or friction will cause the gain in an object's kinetic energy to be less than the work done on it by an applied force, because some energy is dissipated through heating;
13. recall that energy is always conserved;
14. calculate the gain in kinetic energy, **and the speed**, of an object that has fallen through a given height.

MODULE B5: GROWTH AND DEVELOPMENT – OVERVIEW

Genetic technologies are at the cutting edge of contemporary science. Research into proteomics, stem cell technology and cellular growth control is at the forefront of modern medical science. Knowledge and understanding of these areas promise powerful applications to benefit both present and future generations.

The first topic looks at how the structure of DNA allows cells to be accurately copied. Key stages in the cell cycle are identified, and cell division by mitosis and meiosis compared.

The second topic describes the process of protein synthesis, following the one-gene-one-protein hypothesis.

The final topic explains plant and animal development, comparing and contrasting the development of unspecialised cells. The ability of plant meristems to regenerate whole plants is considered, including the effect of plant hormones on their development.

Topics

B5.1 How does an organism produce new cells?

Main processes of the cell cycle.
Comparisons of mitosis and meiosis.

B5.2 How do genes control growth and development within the cell?

Structure of genetic code and mechanism for protein synthesis.

B5.3 How do new organisms develop from a single cell?

Embryo development, cell specialisation in plants and animals.
Plant growth responses.

ICT Opportunities

This module offers opportunities for illustrating the use of ICT in science. For example, imaging cells and observing their growth and development.

Use of ICT in teaching and learning can include:

- animation to illustrate DNA structure, replication, and protein synthesis;
- animation to illustrate cell division;
- video clips to show stages in human development

MODULE B5: GROWTH AND DEVELOPMENT

B5.1 How does an organism produce new cells?

1. recall that DNA has a double helix structure;
 2. understand that cell division by mitosis produces two new cells identical to each other and to the parent cell;
 3. describe the main processes of the cell cycle:
 - cell growth during which:
 - numbers of organelles increase;
 - the chromosomes are copied when the two strands of each DNA molecule separate and new strands form alongside them;
 - mitosis during which:
 - copies of the chromosomes separate;
 - the cell divides;
- ① Candidates are not expected to recall intermediate stages of mitosis.
4. recall that meiosis is a type of cell division that produces gametes;
 5. understand why, in meiosis, it is important that the cells produced only contain half the chromosome number of the parent cell;
 6. understand that a zygote contains a set of chromosomes from each parent.
- ① Candidates are not expected to recall intermediate stages of meiosis.

B5.2 How do genes control growth and development within the cell?

1. recall that the genetic code is in the cell nucleus but proteins are produced in the cell cytoplasm;
 2. understand that genes do not leave the nucleus but a copy of the gene is produced to carry the genetic code to the cytoplasm;
 3. recall that both strands of the DNA molecule are made up of four different bases, which always pair up in the same way;
 4. **explain how the order of bases in a gene is the code for building up amino acids in the correct order to make a particular protein;**
- ① Candidates are not expected to recall details of nucleotide structure, transcription or translation.

MODULE B5: GROWTH AND DEVELOPMENT

B5.3 How do new organisms develop from a single cell?

1. recall that the zygote divides by mitosis to form an embryo;
2. understand that in a human embryo, up to the eight cell stage, all the cells are identical and could produce any sort of cell required by the organism (embryonic stem cells);
3. understand that after this point the cells become specialised and form different types of tissue;
4. understand that although body cells in an organism contain the same genes, many genes in a particular cell are not active because it only produces the specific proteins it needs;
5. **understand that, in carefully controlled conditions of mammalian cloning, it is possible to reactivate inactive genes in the nucleus of a body cell to form cells of all tissue types;**
6. **understand that adult and embryonic stem cells have the potential to produce cells needed to replace damaged tissues;**
7. recall that new cells in plants specialise into cells of roots, leaves or flowers;
8. understand that unlike animal cells some plant cells remain unspecialised and can develop into any type of plant cell;
9. relate the presence of these unspecialised cells to the production of clones of a plant with desirable features, from cuttings;
10. recall that unlike animals, most plants continue to grow in height and width throughout their lives;
11. understand that plant meristems divide to produce cells that result in increased height, length of roots, and girth of the plant;
12. understand that, if the hormonal conditions in their environment are changed, unspecialised plant cells can develop into a range of other tissues (to include xylem and phloem) or organs (to include leaves, roots and flowers);
13. describe how cut stems from a plant can develop roots in the presence of plant hormones (**auxins**) and grow into a complete plant which is a clone of the parent;
14. understand how phototropism increases the plant's chance of survival;
15. **explain phototropism in terms of the effect of light on the distribution of auxin in a shoot tip.**

MODULE C5: CHEMICALS OF THE NATURAL ENVIRONMENT – OVERVIEW

Chemistry is fundamental to an understanding of the scale and significance of human impacts on the natural environment. Knowledge of natural processes makes it possible to appreciate the environmental consequences of agriculture and the polluting effects of extracting and processing minerals.

The module uses environmental contexts to introduce theories of structure and bonding. The first topic explains the characteristics of covalent bonding, ionic bonding and intermolecular forces in the context of the chemicals found in the atmosphere and hydrosphere.

The second topic uses chemicals in the Earth's crust, such as silicon dioxide, to demonstrate and describe the properties of giant structures with strong covalent bonding. The third topic shows that the natural environment is not static but that elements move between the spheres. The study of natural cycles features the nature of some chemicals in the biosphere such as proteins. The final topic covers the distribution, structure and properties of metals through a study of their extraction from ores. This includes the use of relative atomic masses to give a quantitative interpretation of chemical formulae.

Topics

C5.1 What types of chemicals make up the atmosphere and hydrosphere?

The structure and properties of chemicals found in the atmosphere and hydrosphere.

C5.2 What types of chemicals make up the Earth's lithosphere?

Relating the properties of chemicals to their giant structure using examples found in the Earth's lithosphere.

C5.3 Which chemicals make up the biosphere?

Composition of chemicals found in the biosphere and the natural cycles of elements between the spheres.

C5.2 How can we extract useful materials from minerals?

Relating the structure and properties of metals to suitable methods of extraction.

Using ionic theory to explain electrolysis. Discussing issues relating to extraction and recycling.

ICT Opportunities

This module offers opportunities for illustrating the use of ICT in science. For example, modelling molecules and giant structures to explain properties.

Use of ICT in teaching and learning can include:

- animations to show the movement of molecules in a gas over a range of temperatures;
- modelling software to show the shapes of molecules and illustrate giant structures;
- video clips to show metals being extracted on a large scale;
- animations to illustrate the ionic theory of electrolysis.

MODULE C5: CHEMICALS OF THE NATURAL ENVIRONMENT

C5.1 What types of chemicals make up the atmosphere and hydrosphere?

1. recall that dry air consists of gases, some of which are elements (for example oxygen, nitrogen and argon) and some compounds (for example carbon dioxide);
2. recall the symbols for the atoms and molecules of these gases in the air;
3. recall that most non-metal elements and most compounds between non-metal elements are molecular;
4. understand that some molecular elements and compounds have low melting and boiling points;
5. interpret qualitative and quantitative data about the properties of molecular elements and compounds, for example melting and boiling points;
6. understand that the elements and compounds in the air are gases because they consist of small molecules with weak forces of attraction between the molecules;
7. understand that pure molecular compounds do not conduct electricity because their molecules are not charged;
8. **understand that bonding within molecules is covalent and arises from the electrostatic attraction between the nuclei of the atoms and the electrons shared between them: covalent bonds are strong;**
9. translate between representations of molecules including molecular formulae, 2-D diagrams in which covalent bonds are represented by lines and 3-D diagrams for:
 - elements that are gases at 20°C;
 - simple molecular compounds.
10. recall that the Earth's hydrosphere (oceans) consists mainly of water with some dissolved compounds;
11. recall that sea water in the hydrosphere is 'salty' because it contains dissolved ionic compounds called salts;
12. understand that solid ionic compounds form crystals because the ions are arranged in a regular way;
13. understand that ions in a crystal are held together by the attraction between opposite charges: this is ionic bonding;
14. understand how the physical properties of solid ionic compounds (melting point, boiling point, electrical conductivity) relate to their giant, three-dimensional structures;
15. describe what happens to the ions when an ionic crystal dissolves in water;
16. explain that ionic compounds conduct electricity when dissolved in water because the ions are charged and they are able to move around independently in the liquid;
17. **be able to work out the formulae for salts in the sea given a table of charges on ions (for example sodium chloride, magnesium chloride, magnesium sulfate, potassium chloride and potassium bromide.**

MODULE C5: CHEMICALS OF THE NATURAL ENVIRONMENT

C5.2 What types of chemicals make up the Earth's lithosphere?

1. recall that the Earth's lithosphere (the rigid outer layer of Earth made up of the crust and the part of the mantle just below it) is made up of a mixture of minerals;
2. recall that silicon, oxygen and aluminium are very abundant elements in the crust;
3. be able to interpret data about the abundances of elements in rocks;
4. recall that much of the silicon and oxygen is present in the Earth's crust as the compound silicon dioxide;
5. recall the properties of silicon dioxide: (for example hardness, melting point, electrical conductivity and solubility in water);
6. explain the properties of silicon dioxide in terms of a giant structure of atoms held together by strong covalent bonding (for example melting point, boiling point, hardness, solubility and electrical conductivity);
7. understand that silicon dioxide is found as quartz in granite, and is the main constituent of sandstone;
8. understand that some minerals are valuable gemstones because of their rarity, hardness and appearance;
9. **interpret data and explain the uses and properties of other elements and compounds with giant covalent structures (no recall expected).**

MODULE C5: CHEMICALS OF THE NATURAL ENVIRONMENT

C5.3 Which chemicals make up the biosphere?

1. understand that living things are mainly made up from compounds containing the elements carbon, hydrogen, oxygen and nitrogen with small amounts of other elements such as phosphorus and sulfur;
2. interpret data about the percentage composition of carbohydrates, proteins, fats and DNA;
3. recall that carbohydrates, proteins and DNA are molecular;
4. given a diagram of a molecule, identify the elements in the compound and write its formula;
5. interpret flow charts describing chemical changes in cycles between the spheres (for example, the oxygen, carbon or nitrogen cycles) (no recall expected).

MODULE C5: CHEMICALS OF THE NATURAL ENVIRONMENT

C5.4 How can we extract useful metals from minerals?

1. recall that ores are rocks that contain varying amounts of minerals from which metals can be extracted;
2. recall that for some minerals, large amounts of ore need to be mined to recover small percentages of valuable minerals (for example in copper mining);
3. recall examples of metals that can be extracted by heating the oxide with carbon (for example zinc, iron and copper (technical details not required));
4. recall that when a metal oxide loses oxygen it is reduced while the carbon gains oxygen and is oxidised;
5. understand that some metals are so reactive that their oxides cannot be reduced by carbon;
6. be able to balance unbalanced symbol equations;
7. recall and use state symbols: (s), (l), (g) and (aq) in equations;
8. be able to use the Periodic Table to obtain the relative atomic masses of elements;
- 9. be able to calculate the mass of the metal that can be extracted from a mineral given its formula or an equation;**
10. describe electrolysis as the decomposition of an electrolyte with an electric current;
11. understand that electrolytes include molten ionic compounds;
12. describe what happens to the ions when an ionic crystal melts;
13. recall that, during electrolysis, metals form at the negative electrode and non-metals form at the positive electrode;
14. describe the extraction of aluminium from aluminium oxide by electrolysis;
- 15. show that during electrolysis of molten aluminium oxide the positively charged aluminium ions gain electrons from the negative electrode to become neutral atoms;**
- 16. show that during electrolysis of molten aluminium oxide, negatively charged oxide ions lose electrons to the positive electrode to become neutral atoms which then combine to form oxygen molecules;**
- 17. use ionic theory to explain the changes taking place during the electrolysis of a molten salt (limited to using diagrams or symbol equations to account for the conductivity of the molten salt and the changes at the electrodes).**

MODULE C5: CHEMICALS OF THE NATURAL ENVIRONMENT

C5.4 How can we extract useful metals from minerals?

18. recall the properties of metals related to their uses (limited to strength, malleability, melting point and electrical conductivity);
19. explain the properties of metals in terms of a giant structure of atoms held together by strong metallic bonding;
- 20. understand that in a metal crystal there are positively charged ions held closely together by a sea of electrons that are free to move;**
21. evaluate, given appropriate information, the impacts on the environment that can arise from the extraction, use and disposal of metals.

MODULE P5: ELECTRIC CIRCUITS – OVERVIEW

Known only by its effects, electricity provides an ideal vehicle to illustrate the use and power of scientific models. During the course of the 20th century electrical engineers completely changed whole societies, by designing systems for electrical generation and distribution, and a whole range of electrical devices.

In this module candidates learn how scientists visualise what is going on inside circuits and so predict circuit behaviour. The idea of current as a flow of electrons is introduced in the first topic. In the second topic, useful models of charge moving through circuits driven by a voltage and against a resistance, include that of a liquid in a narrow tube and a belt between pressure pads. A more general understanding of voltage as potential difference is developed in the third topic and a model based on height differences can be introduced.

The concepts of current and voltage are further developed in the topic on generation of electricity. The final topic relates these concepts to power, and introduces the idea of efficiency of electrical appliances.

Topics

P5.1 Electric current – a flow of what?

Electric current as a flow of charge; how the charge moves.

P5.2 What determines the size of the current in an electric circuit?

Voltage; current and resistance; series and parallel circuit; working out resistance.

P5.3 How do parallel and series circuits work?

Voltage and how it behaves in a series circuit; current and how it behaves in a parallel circuit.

P5.4 How is mains electricity produced?

Including voltages and currents; how generators work; ac and dc.

P5.5 How much electrical energy do we use at home?

The relationship between power, voltage and current; calculating the energy transferred and the efficiency of the transfer.

ICT Opportunities

This module offers opportunities for illustrating the use of ICT in science, for example:

- studying electric fields between charged particles and surfaces;
- using computer simulations to construct virtual circuits and test their behaviour.

Use of ICT in teaching and learning can include:

- modelling software to explore electric circuit theory;
- animation to illustrate model of electric current as flowing charges.

MODULE P5: ELECTRIC CIRCUITS

P5.1 Electric current - a flow of what?

1. explain that when two objects are rubbed together and become charged, electrons are transferred from one object to the other;
2. recall that there are repulsive forces between objects with similar charges, and attractive forces between objects with opposite charges;
3. explain simple electrostatic effects in terms of attraction and repulsion between charges;
4. recall that electrons are negatively charged;
5. recall that electric current is a flow of charge;
6. recall that electric current is measured in amperes;
7. explain that in an electric circuit the components and wires are full of charges that are free to move;
8. explain that when a circuit is made the battery causes these free charges to move, and that they are not used up but flow in a continuous loop;
9. recall that in metallic conductors an electric current is a movement of free electrons;
10. explain that in metal conductors there are lots of charges free to move but in an insulator there are few charges free to move.

MODULE P5: ELECTRIC CIRCUITS

P5.2 What determines the size of the current in an electric circuit?

1. recall that the larger the voltage of the battery in a given circuit, the bigger the current;
2. explain that components (for example resistors, lamps, motors) resist the flow of charge through them;
3. recall that the larger the resistance in a given circuit, the smaller the current will be;
4. recall that the resistance of connecting wires is so small that it can usually be ignored;
5. recall that resistors get hotter when electric current passes through them, **and that this heating effect is caused by collisions between the moving charges and stationary atoms in the wire;**
6. recall that this heating effect makes a lamp filament hot enough to glow;
7. describe how the resistance of an LDR varies with light intensity;
8. describe how the resistance of a thermistor (ntc only) varies with temperature;
9. recognise and use the electrical symbols for a cell, power supply, filament lamp, switch, LDR, fixed and variable resistor, thermistor, ammeter and voltmeter;
10. explain that two (or more) resistors in series have more resistance than one on its own, because the battery has to push charges through both of them;
11. explain that two (or more) resistors in parallel provide more paths for charges to flow along than one resistor on its own, so the total resistance is less and the current is bigger;
12. use the equation:
 - $\text{resistance (ohm, } \Omega) = \frac{\text{voltage (volt, V)}}{\text{current (ampere, A)}}$
- ① **Rearrangement of the equation is expected only on higher tier.**
13. describe in words, or using a sketch graph, how the current varies with voltage in components whose resistance stays constant.

MODULE P5: ELECTRIC CIRCUITS

P5.3 How do parallel and series circuits work?

1. describe how a voltmeter should be connected to measure the potential difference between any two chosen points;
2. recall that the voltage of a battery (measured in V) provides a measure of the 'push' of the battery on the charges in the circuit;
3. recall that potential difference is another term for voltage;
4. relate the potential difference between two points in the circuit to the energy transferred to, or from, a given amount of charge as it moves between these points;
5. describe the effect on voltage and current of adding further batteries in series **and in parallel** with original one;
6. understand that when several components are connected in series to a battery:
 - the current through each component is the same;
 - the potential differences across the components add up to the potential difference across the battery (**because the total energy transferred to each unit of charge by the battery must equal the amount transferred from it to other components**);
 - the potential difference is largest across the component with the greatest resistance, **because more energy is transferred by the charge flowing through a large resistance than through a small one**;
7. recall that when several components are connected in parallel directly to a battery:
 - **the potential difference (voltage) across each component is equal to the potential difference of the battery**;
 - **the current through each component is the same as if it were the only component present**;
 - the total current from (and back to) the battery is the sum of the currents through each of the parallel components;
 - the current is smallest through the component with the largest resistance, **because the same battery voltage causes more current through a smaller resistance than a bigger one**.

MODULE P5: ELECTRIC CIRCUITS

P5.4 How is mains electricity produced?

Candidates will be assessed on their ability to:

1. recall that mains electricity is produced by generators;
2. recall that generators produce a voltage by a process called electromagnetic induction;
3. recall that when a magnet is moving into a coil of wire a voltage is induced across the ends of the coil;
4. recognise that if the ends of the coil are connected to make a closed circuit, a current will flow round the circuit;
5. recall that if the magnet is moving out of the coil, or the other pole of the magnet is moving into it, there is a voltage induced in the opposite direction;
6. explain that a changing magnetic field caused by changes in the current in one coil of wire can induce a voltage in a neighbouring coil;
7. describe the construction of a transformer as two coils of wire wound on an iron core;
8. recall that a transformer can change the size of an alternating voltage;
9. **be able to use the equation:**

$$\frac{V_p}{V_s} = \frac{N_p}{N_s}$$

10. describe how, in a generator, a magnet or electromagnet is rotated within a coil of wire to induce a voltage across the ends of the coil;
11. understand that the size of this induced voltage can be increased by:
 - increasing the speed of rotation of the magnet or electromagnet;
 - increasing the strength of its magnetic field;
 - increasing the number of turns on the coil;
 - placing an iron core inside the coil;
12. **describe how the induced voltage across the coil of a generator changes during each revolution of the magnet or electromagnet and explain that the current produced in an external circuit is an alternating current (a.c.);**
13. understand that the current from a battery is always in the same direction: it is a direct current (d.c.);
14. recall that mains electricity is an a.c. supply;
15. **explain that a.c. is used because it is easier to generate than d.c., and can be distributed more efficiently;**
16. recall that the mains supply voltage to our homes is 230 volts.

MODULE P5: ELECTRIC CIRCUITS

P5.5 How much electrical energy do we use at home?

1. explain that when electric charge flows through a component (or device), energy is transferred to the component;
2. recall that the power (in watt, W) is a measure of the rate at which an appliance or device transfers energy;
3. use the following equation to calculate energy transfer in joules and kilowatt-hours:
 - $$\begin{array}{rcl} \text{energy transferred} & = & \text{power} \quad \times \quad \text{time} \\ \text{(joule, J)} & & \text{(watt, W)} \quad \quad \quad \text{(second, s)} \\ \text{(kilowatt hour, kWh)} & & \text{(kilowatt, kW)} \quad \quad \quad \text{(hour, h)} \end{array}$$
4. use the equation:
 - $$\begin{array}{rcl} \text{power} & = & \text{potential difference (voltage)} \times \text{current} \\ \text{(watt, W)} & & \text{(volt, V)} \quad \quad \quad \text{(ampere, A)} \end{array}$$
- ① **Transformation of these equations is only required on the higher tier.**
5. know that a joule is a very small amount of energy, so a domestic electricity meter measures the energy transfer in kilowatt hours;
6. calculate the cost of electrical energy given the power, the time and the cost per kilowatt hour;
7. use the following equation in the context of different electrical appliances:
 - $$\text{efficiency} = \frac{\text{energy usefully transferred}}{\text{total energy supplied}} \times 100\%$$

MODULE B6: BRAIN AND MIND – OVERVIEW

How the human brain functions remains largely unknown. Neuroscience is an area at the frontiers of medical research, and has huge potential impact for an aging population.

This module begins by looking at how, in order to survive, simple organisms respond to changes in their environment. The nervous system of multicellular animals is also considered.

The second topic considers how information is transmitted from receptor cells to effector cells, including a simple description of chemical transmission across synapses. Simple, learnt and modified reflexes are introduced in the third topic, with reference to survival and adaptation.

The fourth topic takes a closer look at the brain, and how neuron pathways become 'preferred' although potential pathways are available to allow for adaptation to new situations. The fifth topic illustrates specialised areas of the brain, methods scientists have used to map the cerebral cortex and introduces a basic understanding of memory. Finally the effects of drugs on synapses in the brain are explored (for example, Ecstasy)

Topics

B6.1 How do organisms respond to changes in their environment?

Co-ordination of responses to stimuli via the central nervous system.

B6.2 How is information passed through the nervous system?

Structure of motor neurons

Transmission of electrical impulses including synapse.

B6.3 What are reflex actions?

Simple reflex actions for survival, mechanism of a reflex arc conditioned reflexes.

B6.4 How do humans develop more complex behaviour?

Formation of neuron pathways and learning through repetition.

B6.5 What do we know about the way in which the brain co-ordinates our senses?

Mapping brain function, Models for understanding memory.

B6.6 How do drugs affect our nervous systems?

Effects of Ecstasy on synapse action.

ICT Opportunities

This module offers opportunities for illustrating the use of ICT in science, for example:

- observing and recording human and animal behaviour;
- logging, recording and displaying physiological data.

Use of ICT for teaching and learning can include:

- video clips to illustrate patterns in the behaviour of living things;
- animation to explain synapse function and the effects of drugs on synapses;
- the internet to research behaviour and memory.

MODULE B6: BRAIN AND MIND

B6.1 How do organisms respond to changes in their environment?

1. recall that a stimulus is a change in the environment of an organism;
2. understand that animals respond to stimuli in order to keep themselves in favourable conditions;
3. understand that the central nervous system (CNS) coordinates an animal's responses via:
 - sensory neurons carrying impulses from receptors to the CNS;
 - motor neurons carrying impulses from the CNS to effectors;
4. understand that receptors and effectors can form part of complex organs, for example:
 - light receptor cells in the retina of the eye;
 - hormone secreting cells in a gland;
 - muscle cells in a muscle;
5. recall that in the mammalian nervous system the CNS (brain and spinal cord) is connected to the body via the peripheral nervous system (sensory and motor neurons).

B6.2 How is information passed through the nervous system?

1. recall that neurons transmit electrical impulses when stimulated;
2. recall that in motor neurons the cytoplasm forms a long fibre surrounded by a cell membrane called an axon;
3. understand that some axons are surrounded by a fatty sheath, which insulates the neuron from neighbouring cells and increases the speed of transmission of a nerve impulse;
4. recall that there are gaps between adjacent neurons called synapses;
5. **understand that at the end of a sensory neuron an impulse triggers the release of chemicals into the synapse, which diffuse across and bind to receptor molecules on the membrane of a motor neuron;**
6. **understand that the receptor molecules only bind to specific chemicals, initiating a nerve impulse in the motor neuron.**

MODULE B6: BRAIN AND MIND

B6.3 What are reflex actions?

1. recall that simple reflexes produce rapid involuntary responses;
2. understand the nervous pathway of a reflex arc;
3. understand that simple reflexes ensure that an animal will respond to a stimulus in a way that is most likely to result in its survival, to include finding food, sheltering from predators, and finding a mate;
4. understand that simple animals rely on reflex actions for the majority of their behaviour;
5. understand that the disadvantage of this simple behaviour is that these animals have difficulty responding to new situations;
6. recall examples of simple reflexes in humans, to include newborn reflexes, pupil reflex;
7. **understand that a reflex response to a new stimulus can be learned by introducing a secondary stimulus in association with the primary stimulus, e.g. Pavlov's dogs (conditioned reflex action);**
8. **understand that in a conditioned reflex the final response has no direct connection to the stimulus;**
9. **understand that some conditioned reflexes increase the animal's chances of survival, e.g. rejection by birds of caterpillars with particular colouring;**
10. **recall that in some circumstances the brain can modify a reflex response via a neuron to the motor neuron of the reflex arc, to include keeping hold of a hot dinner plate.**

MODULE B6: BRAIN AND MIND

B6.4 How do humans develop more complex behaviour?

1. recall that mammals have a complex brain of billions of neurons that allows learning by experience, including social behaviour;
2. understand that during development the interaction between mammals and their environment results in neuron pathways forming in the brain;
3. understand learning as the result of experience where certain pathways in the brain will become more likely to transmit impulses than others;
4. understand that this is why some skills may be learnt through repetition;
5. understand that the variety of potential pathways in the brain makes it possible for the animal to adapt to new situations;
6. **understand that there is evidence to suggest that children may only acquire some skills at a particular age, to include language development in feral children.**

MODULE B6: BRAIN AND MIND

B6.5 What do we know about the way in which the brain co-ordinates our senses?

1. recall that the cerebral cortex is the part of our brain most concerned with intelligence, memory, language and consciousness;
2. recall that a variety of methods have been used by scientists to map the regions of the cortex (including studies of patients with brain damage, studies in which different parts of the brain are stimulated electrically and, more recently, MRI brain scans);
3. describe memory as the storage and retrieval of information;
4. understand that verbal memory can be divided into short-term memory and long-term memory;
5. **understand that humans are more likely to remember information if they can see a pattern in it (or impose a pattern on it), if there is repetition of the information, especially over an extended period of time, or if there is a strong stimulus associated with it, including colour, light, smell, sound;**
6. understand that scientists have produced models for memory but so far none of these has been able to provide an adequate explanation.

B6.6 How do drugs affect our nervous systems?

1. recall that some drugs and toxins affect the transmission of impulses across synapses;
2. **understand that Ecstasy (MDMA) blocks the sites in the brain's synapses where the chemical serotonin is removed;**
3. **understand that the mood-enhancing effects of Ecstasy are due to the subsequent increase in serotonin concentration.**

MODULE C6: CHEMICAL SYNTHESIS – OVERVIEW

Synthesis provides many of the chemicals that people need for food processing, health care, cleaning and decorating, modern sporting materials and many other products. The chemical industry today is developing new processes for manufacturing these chemicals more efficiently and with less impact on the environment.

In this context, the module explores related questions which chemists have to answer: 'How much?' and 'How fast?' in the context of the chemical industry. Quantitative work includes the calculation of yields from chemical equations and the measurement of rates of reaction.

A further development of ionic theory shows how chemists use this theory to account for the characteristic behaviours of acids and alkalis.

Topics

C6.1 Chemicals and why we need them

The scale and importance of the chemical industry. Acids, alkalis and their reactions.

Neutralisation explained in terms of ions.

C6.2 Planning, carrying out and controlling chemical synthesis

Planning chemical syntheses. Procedures for making pure inorganic products safely. Comparing alternative routes to the same product.

Calculating reacting quantities and yields.

Measuring purity by simple titration. Controlling the rate of change.

ICT Opportunities

This module offers opportunities for illustrating the use of ICT in science. For example, logging data, storing it and displaying it in a variety of formats for analysis.

Use of ICT in teaching and learning can include:

- video clips to illustrate the manufacture of chemicals on a large-scale in industry;
- sensors and data loggers to monitor neutralisation reactions and the rates of chemical changes.

MODULE C6: CHEMICAL SYNTHESIS

C6.1 Chemicals and why we need them

1. understand the importance of chemical synthesis to provide food additives, fertilisers, dyestuffs, paints, pigments and pharmaceuticals;
2. interpret information about the sectors, scale and importance of chemical synthesis in industry and in laboratories;
3. recall the formulae of the following chemicals: chlorine gas, hydrogen gas, nitrogen gas, oxygen gas, hydrochloric acid, nitric acid, sulfuric acid, sodium hydroxide, sodium chloride, sodium carbonate, potassium chloride, magnesium oxide, magnesium hydroxide, magnesium carbonate, magnesium sulfate, calcium carbonate, calcium chloride;
4. **work out the formulae of ionic compounds given the charges on the ions (from C4);**
5. **work out the charge on one ion given the formula of a salt and the charge on the other ion (from C4);**
6. recall the main hazard symbols and understand the safety precautions to use when handling hazardous chemicals;
7. recall examples of pure acidic compounds which are solids (citric and tartaric acids), liquids (sulfuric, nitric and ethanoic acids) or gases (hydrogen chloride);
8. recall that common alkalis include the hydroxides of sodium, potassium and calcium;
9. recall the pH scale;
10. recall the use of indicators and pH meters to measure pH;
11. recall the characteristic reactions of acids that produce salts to include the reactions with metals, oxides, hydroxides and carbonates;
12. write balanced equations with state symbols to describe the characteristic reactions of acids;
13. recall that the reaction of acid with an alkali to form a salt is a neutralisation reaction;
14. **balance unbalanced symbol equations;**
15. explain that acidic compounds produce aqueous hydrogen ions, $\text{H}^+(\text{aq})$, in water;
16. explain that alkaline compounds produce aqueous hydroxide ions, $\text{OH}^-(\text{aq})$, when they dissolve in water;
17. write down the formula of the salt produced given the formulae of the acid and the alkali;
18. explain that during a neutralisation reaction, the hydrogen ions from the acid react with hydroxide ions from the alkali to make water:
 $\text{H}^+(\text{aq}) + \text{OH}^-(\text{aq}) \rightarrow \text{H}_2\text{O}(\text{l})$

MODULE C6: CHEMICAL SYNTHESIS

C6.2 Planning, carrying out and controlling chemical synthesis

1. identify the stages in a given chemical synthesis of an inorganic compound including:
 - choosing the reaction or series of reactions to make the required product;
 - carrying out a risk assessment;
 - **working out the quantities of reactants to use;**
 - carrying out the reaction in suitable apparatus in the right conditions (such as temperature, concentration or the presence of a catalyst);
 - separating the product from the reaction mixture,
 - purifying the product.
 - measuring the yield and checking the purity of the product;
2. understand the purpose of these techniques: dissolving, crystallisation, filtration, evaporation, drying in an oven or dessicator;
3. understand the importance of purifying chemicals and checking their purity;
4. understand that a balanced equation for a chemical reaction shows the relative numbers of atoms and molecules of reactants and products taking part in the reaction;
5. understand that the relative atomic mass of an element shows the mass of its atom relative to the mass of other atoms;
6. be able to use the Periodic Table to obtain the relative atomic masses of elements;
7. calculate the relative formula mass of a compound using the formula and the relative masses of the atoms it contains;
8. **calculate the masses of reactants and products from balanced equations;**
9. calculate percentage yields given the actual and the theoretical yield;
10. describe how to carry out an acid-alkali titration accurately (solid sample weighed out into a titration flask, dissolved in water and then titrated with acid or alkali from a burette);
- ① Making up of standard solutions is not required.
11. substitute results in a given formula to interpret titration results quantitatively.

MODULE C6: CHEMICAL SYNTHESIS

C6.2 Planning, carrying out and controlling chemical synthesis

12. understand why it is important to control the rate of a chemical synthesis (to include safety and economic factors);
13. explain the term: 'rate of chemical reaction';
14. describe methods for following the rate of a reaction (for example by collecting a gas, weighing the reaction mixture or observing the formation of a colour or precipitate);
15. interpret results from experiments that investigate rates of reactions;
16. recall that reaction rates vary with the particle size of insoluble chemicals, the concentration of solutions of soluble chemicals and the temperature of the reaction mixture;
17. understand that catalysts speed up chemical reactions while not being used up in the chemical changes;
18. interpret information about the control of rates of reaction in chemical synthesis;
19. **use simple collision theory to explain how rates of reaction depend on the concentration of solutions of soluble chemicals.**

MODULE P6: THE WAVE MODEL OF RADIATION – OVERVIEW

Wave behaviour explains a great many phenomena, both natural and artificial, for all waves have properties in common.

The first topic introduces a basic vocabulary for describing waves. Reflections and refractions of water serve as models for the behaviour of light and sound in the second topic. The third topic explores the electromagnetic spectrum, giving examples of properties and contemporary uses of different waves.

The final topic is a first step towards an understanding of modern communications systems.

Topics

P6.1 What are waves?

Transverse and longitudinal waves, frequency, wavelength, amplitude, wave speed.

P6.2 Why do scientists think that light and sound are waves?

Reflection, refraction, effect of the medium; behaviour of water waves related to sound and light waves.

P6.3 Do all types of electromagnetic radiation behave in the same way?

Wavelength and frequency of the parts of the electromagnetic spectrum; properties and uses of each part of the electromagnetic spectrum.

P6.4 How is information added to a wave?

Analogue and digital signals to carry information; the quality of each type of signal.

ICT Opportunities

This module offers opportunities for illustrating the use of ICT in science, for example:

- simulating the shape of wavefronts and interference effects in a variety of engineering applications;
- analysing wave reflections in seismic explorations.

Use of ICT in teaching and learning can include:

- video clips to show examples of wave motion;
- animation to show the behaviour of waves in ripple tanks;
- modelling software to investigate the implications of the wave equation;
- spreadsheets to model features of analogue and digital communications systems;
- sound files, which can be listened to, displayed graphically and modified to illustrate AM and FM modulation and the effects of noise.

MODULE P6: THE WAVE MODEL OF RADIATION

P6.1 What are waves?

1. recall that a wave consists of disturbances that transfer energy in the direction that the wave travels, without transferring matter;
2. describe the differences between a transverse and a longitudinal wave;
3. recall that the frequency of the waves, in hertz (Hz), is the number of waves each second that are made by the source, or that pass through any particular point in the medium;
4. recall that the wavelength of waves is the distance between the same point on two adjacent disturbances;
5. recall the amplitude of waves is the distance from the top of the crest or bottom of the trough to the undisturbed position;
6. draw and interpret diagrams showing the amplitude and the wavelength of waves;
7. use the equation:
 - $$\begin{array}{ccccc} \text{wave speed} = & & \text{frequency} & \times & \text{wavelength} \\ & & \text{(hertz, Hz)} & & \text{(metre, m)} \\ & & & & \text{(metre per second m/s)} \end{array}$$
- ① **Rearrangement of the equation is only expected on the higher tier.**
8. recall that the speed of a wave is usually independent of its frequency and amplitude.

MODULE P6: THE WAVE MODEL OF RADIATION

P6.2 Why do scientists think that light and sound are waves?

1. draw and interpret diagrams showing the reflection of plane water waves and narrow beams of sound or light from a plane reflector;
2. recognise that wave speed is affected by what waves are travelling along or through (the medium) and that the speed will change if a wave moves from one medium into another;
3. explain how a change in the speed of a wave causes a change in wavelength since the frequency of the waves cannot change, and how this may cause a change in direction;
4. draw and interpret diagrams showing the refraction of plane water waves, or beams of light or sound, when they cross a boundary between different media, relating the change of direction to the change in wave speed;
5. recall that the refraction of light waves and sound waves can be explained by a change in their speed when they pass into a different medium;
6. recall that light rays for which the angle of refraction would be greater than 90 degrees cannot leave the medium they are in, and are reflected and that this is known as total internal reflection;
7. recall that waves can spread out at a narrow gap and that this is called diffraction;
8. draw and interpret diagrams showing wave diffraction through gaps;
9. recall that light can be diffracted but needs a very small gap, comparable to the wavelength of the wave;
10. recall that where two waves meet, their effects add and that this is called interference;
11. recall that where two waves arrive in step they reinforce and where they arrive out of step they cancel out;
12. recall that two light beams can be shown to produce an interference pattern;
13. explain interference patterns in terms of constructive and destructive interference;
14. explain how the diffraction and interference of light and sound are evidence of their wave natures.

MODULE P6: THE WAVE MODEL OF RADIATION

P6.3 Do all types of electromagnetic radiation behave in the same way?

1. recall that the different colours of light in the spectrum have different frequencies (and therefore wavelengths);
2. list the parts of the whole electromagnetic spectrum in order of frequency or wavelength (radio waves, microwave, infrared, visible light, ultraviolet , X-rays, gamma radiation);
3. recall that the energy delivered by each photon in a beam of electromagnetic radiation increases with the frequency of the electromagnetic waves;
4. understand that the intensity of a beam of electromagnetic radiation (the energy it delivers per second) depends on the number of photons arriving every second and the amount of energy carried by each photon;
5. know that all types of electromagnetic radiation travel at exactly the same, very high, speed through space (a vacuum);
6. recall an important difference between electromagnetic waves and sound waves: electromagnetic waves can travel through empty space, but sound waves can only travel through a substance (solid, liquid or gas);
7. understand that different frequencies of electromagnetic radiation are used for different purposes due to the difference in reflection, absorption or transmission by different materials to include:
 - radio waves are not strongly absorbed by the atmosphere so can be used to carry information for radio and TV programmes;
 - some microwaves are strongly absorbed by water molecules and so can be used to heat objects containing water;
 - satellite dishes are made of metal because metals reflect microwaves well;
 - X-rays are absorbed by dense materials so can be used to produce shadow pictures of bones in our bodies or of objects in aircraft passengers' luggage;
 - light and infrared radiation can be used to carry information along optical fibres because they travel through without becoming significantly weaker.

MODULE P6: THE WAVE MODEL OF RADIATION

P6.4 How is information added to a wave?

1. recall that signals can be carried not only by radio waves and microwaves through the Earth's atmosphere and through space but also by light waves and infrared waves through optical fibres;
2. understand that if a wave is to carry information the waves must be made to vary in amplitude or frequency, and that the information is carried by the pattern of the variation, recall that this process is called modulation;
3. interpret diagrams showing how a sound wave can be used to vary the amplitude or frequency of a radio wave, with a pattern that matches its own frequency;
4. recall that a signal which varies continuously is called an analogue signal;
5. recall that the job of the receiver is to reproduce the original sound from the pattern of the variation;
- ① Details of any transmission or receiver systems are not required.
6. recall that sound (or other information) can be transmitted digitally (digital signal);
7. recall that, in digital transmission, the sound is often converted into a digital code made up from just two symbols (0 and 1);
8. recall that this coded information can be used to control the short bursts of waves (pulses) produced by a source (0 = no pulse, 1 = pulse);
9. recall that when the waves are received, the pulses are decoded to produce a copy of the original sound wave;
10. know that an important advantage of digital signals over analogue signals is that they can transmit information with higher quality, i.e. the signal is less affected by the transmission process;
11. understand that all signals, as they travel, decrease in intensity (their amplitude becomes smaller), so they may have to be amplified;
12. know that random additions to the original signal (noise) may be picked up as a signal travels, reducing its quality;
13. know that, when a signal is amplified, any noise it has picked up is also amplified;
14. understand that, with digital signals, 'on' and 'off' states can usually still be recognised despite any noise that is picked up. The signal can therefore be cleaned up to remove the noise and restore the original pattern of 'on's and 'off's;
15. be able to use these ideas to interpret information about analogue and digital transmission **and to explain why information can be transmitted digitally with higher quality.**

4 Scheme of Assessment

4.1 Units of Assessment

GCSE Additional Science J631

Unit 1: Additional Science A Unit 1 – modules B4, C4, P4 (A215)

16.7% of the total GCSE marks
40 minutes written paper
42 marks

This question paper:

- is offered in Foundation and Higher Tiers;
- focuses on B4, C4 and P4;
- uses objective style questions throughout (there is no choice of questions);
- assesses knowledge and understanding of the specification content and application of that knowledge and understanding.

Unit 2: Additional Science A Unit 2 – modules B5, C5, P5 (A216)

16.7% of the total GCSE marks
40 minutes written paper
42 marks

This question paper:

- is offered in Foundation and Higher Tiers;
- focuses on B4, C4 and P4;
- uses objective style questions throughout (there is no choice of questions);
- assesses knowledge and understanding of the specification content and application of that knowledge and understanding.

Unit 3: Additional Science A Unit 3 – modules B6, C6, P6 (A217)

16.7% of the total GCSE marks
40 minutes written paper
42 marks

This question paper:

- is offered in Foundation and Higher Tiers;
- focuses on B4, C4 and P4;
- uses objective style questions throughout (there is no choice of questions);
- assesses knowledge and understanding of the specification content and application of that knowledge and understanding.

Unit 4: Additional Science Unit 4 – Ideas in Context (A218)

16.7% of the total GCSE marks
45 minutes written paper
40 marks

This question paper:

- incorporates pre-release material;
- focuses on three modules, one each of biology, chemistry and physics, with the subject made clear by the pre-release material;
- assesses knowledge and understanding of the specification content and application of that knowledge and understanding;
- uses structured questions throughout (there is no choice of questions);
- Includes some marks for communication skills.

Unit 5: Additional Science A Unit 5 – Practical Investigation (A220)

33.3% of the total GCSE marks
skills assessment
40 marks

- This unit comprises five strands, which together are used to assess a complete investigative task.
- This unit is assessed by teachers, internally standardised and then externally moderated by OCR.

4.2 Unit Options

To claim the qualification GCSE Additional Science (J631) candidates can:

take Units 1 to 5 as above (i.e. Units A215, A216, A217, A218 and A220);

or

take Unit 2 from each of Biology, Chemistry and Physics plus Units 4 and 5 from this specification (i.e. Units A222, A322, A332, A218 and A220).

4.3 Tiers

Units 1, 2, 3 and 4 are set in one of two tiers: Foundation Tier and Higher Tier. Foundation Tier papers assess Grades G to C and Higher Tier papers assess Grades D to A*. An allowed grade E may be awarded on the Higher Tier components. Candidates are entered for either the Foundation Tier or the Higher Tier using option codes F and H. Unit 5 (Practical Investigation) is not tiered.

Candidates may enter Units 1, 2, 3 and 4 at different tiers, so for example, a candidate may take A215F, A216F and A217H, A218F.

4.4 Assessment Availability

There are two examination sessions each year, in January and June.

	Unit 1 (A215)	Unit 2 (A216)	Unit 3 (A217)	Unit 4 (A218)	Unit 5 (A220)
January 2007	-	-	-	-	-
June 2007	✓	✓	-	-	-
January 2008	✓	✓	✓	-	-
June 2008	✓	✓	✓	✓	✓

After June 2008, Units A215, A216 and A217 will be available in the January and June sessions. The Ideas in Context paper, Unit A218, and skills assessment, Unit A220, will only be available in the June sessions.

The Foundation and Higher tier papers covering the same unit will be timetabled on the same day, and will commence at the same time. The papers timetabled simultaneously will contain common questions, or part questions, targeting the overlapping grades C and D.

4.5 Assessment Objectives

The Assessment Objectives describe the intellectual and practical skills which candidates should be able to demonstrate, in the context of the prescribed content. Candidates should demonstrate communication skills, including ICT, using scientific conventions (including chemical equations) and mathematical language (including formulae).

Assessment Objective 1 (AO1): Knowledge and understanding of science and how science works

Candidates should be able to:

- demonstrate knowledge and understanding of the scientific facts, concepts techniques and terminology in the specification;
- show understanding of how scientific evidence is collected and its relationship with scientific explanations and theories;
- show understanding of how scientific knowledge and ideas change over time and how these changes are validated.

Assessment Objective 2 (AO2): Application of skills knowledge and understanding

Candidates should be able to:

- apply concepts, develop arguments or draw conclusions related to familiar and unfamiliar situations;
- plan a scientific task, such as a practical procedure, testing an idea, answering a question or solving a problem;
- show understanding of how decisions about science and technology are made in different situations, including contemporary situations and those raising ethical issues;
- evaluate the impact of scientific developments or processes on individuals, communities or the environment.

Assessment Objective 3 (AO3): Practical, enquiry and data-handling skills

Candidates should be able to:

- carry out practical tasks safely and skillfully;
- evaluate the methods they use when collecting first-hand and secondary data;
- analyse and interpret qualitative and quantitative data from different sources;
- consider the validity and reliability of data in presenting and justifying conclusions.

Weighting of Assessment Objectives

All figures given are for guidance only and have a tolerance of $\pm 3\%$.

Assessment Objectives	Weighting
AO1: Knowledge and understanding	29.5%
AO2: Application of knowledge and understanding, analysis and evaluation	36.6%
AO3: Enquiry	33.9%

The relationship between the units and the assessment objectives of the scheme of assessment is shown in the following grid.

	Assessment Objective Weightings by Unit			
	AO1	AO2	AO3	Total
A215, A216, A217	22.5%	24.1%	3.5%	50.1%
A218	5%	6.5%	5.2%	16.7%
A220	2%	6%	25.2%	33.2%
Overall	29.5%	36.6%	33.9%	100%

4.6 Quality of Written Communication

Candidates are expected to:

- ensure text is legible and that spelling, punctuation and grammar are accurate, so that meaning is clear;
- present relevant information in a form that suits its purpose;
- use a suitable structure and style of writing.

Candidates' quality of written communication will be assessed in the Ideas in Context paper (Unit A218) and in the Practical Investigation (Unit A220)

5 Skills Assessment

5.1 Nature of Skills Assessment

Rationale

The use of practical investigations to assess skills in science was based on research in a number of centres, particularly the University of Durham. For more than 10 years, it has formed the basis of coursework assessment for National Curriculum science.

Investigations require the drawing together of skills in planning, collecting data, interpreting data and evaluation. They provide an effective and valid assessment instrument for a course which is seen as a basis for further studies and possible future careers in science. However, the regulations used at Key Stage 4 over the past 5-year cycle have been constructed in a way which has restricted the variety of work attempted and has led to rather mechanical 'criterion matching', rather than genuine open-ended work.

For this specification, the basic structure of investigations is retained, but the emphasis on prediction is removed, allowing a much wider range of activities and approaches. A different marking style has been developed, drawing more on professional judgment of teachers.

The task aims to motivate candidates and help them to appreciate the importance of having a clear and manageable question, to learn how to choose equipment and use it appropriately, and to design suitable apparatus for making observations and measurements. First-hand experience of the problems of collecting valid and reliable data can give candidates a better sense of what the difficulties really are, and a 'feel' for how great they are in specific cases, and provide a context for beginning to understand how to tackle and perhaps overcome these.

Introduction

Candidates are required to complete one single practical investigation. The Investigation, accounts for 33% of the marks for this specification. It is assessed by teachers, internally standardised, and then externally moderated.

Within this Science suite, investigative work is designed to have a broad definition. In addition to confirming the predicted effect of a variable on a system over a range, the definition also includes more speculative investigation of systems where no clear prediction can be made in advance, e.g. where there is little relevant explanatory theory available in the course, or where the experimental material is likely to be variable, for example in surveys of distribution of species. It also includes tasks which involve determining the consistency of measurements e.g. comparing the characteristics of different artefacts, obtaining evidence for the 'normal' variation in respiratory peak flow-rates of an individual, etc.

The initial stimulus for an investigation should arise from class teaching or discussion which ensures that candidates are aware of suitable practical techniques and have some relevant background theoretical knowledge.

This unit of the assessment is based on complete, first-hand practical investigations. Candidates may complete as many investigations as they wish during the course. The final mark will be the total for the highest-scoring single piece of work assessed. It is not permitted to aggregate together marks taken from different investigations. Where appropriate, first-hand data collected by the candidate may be supplemented by secondary data from other sources. In such cases, credit for collecting data should be based on the overall quality of all the data obtained or selected.

Marks are awarded for 5 strands of the investigation, with each strand marked on a scale of 0 – 8.

5.2 Marking Internally Assessed Work

Arrival at Strand Marks

The method of marking the skills assessment is the same across this Science suite.

The award of marks is based on the professional judgement of the science teacher, working within a framework of descriptions of performance. Within each strand, each line in the marking grids represents a different aspect of performance. For each of these, a series of four descriptions of performance illustrates what might be expected for candidates working at different levels.

Marking decisions should be recorded on marking grids. A master copy is provided in the skills assessment guidance booklet. The completed grid serves as a cover-sheet for the work if it is required for moderation.

Candidates may not always report their work in a particular order. So, evidence of achievement in a strand may be located almost anywhere in the work. Thus, it is necessary to look at the whole piece of work for evidence of each strand in turn.

Within any one strand, each aspect should be considered in turn. A tick on the grid should be used to indicate the performance statement that best matches the work.

Where the maximum mark is 8, intermediate marks 1, 3, 5 or 7 can be used where performance exceeds that required by one statement, but does not adequately match that required by the next higher statement (e.g. if the work significantly exceeds what is required for 4 marks, but does not reach the standard for 6, then the tick should be placed on the dividing line between the 4 and 6 mark boxes).

Where a decision is based partly on the teacher's observation of the candidate at work, the work should be annotated to record this at an appropriate point.

In some cases, in order to allow credit for the widest possible variety of activities, an aspect of performance is represented by two (or more) rows of mark descriptors. In such cases, where a row is not relevant or appropriate for a particular activity, it should be left blank and excluded from the 'best-fit' marking judgement and the more appropriate alternative row used.

When each aspect of the performance within a strand have been assessed in this way, the pattern of achievement is interpreted by a 'best-fit' judgement to give a mark for that strand.

This method of marking can be applied even where there is a wide variation between performance in different aspects. Thus, weak performance in one aspect need not depress marks too far if other aspects show better performance.

Arrival at the Final Mark Submitted

This unit is designed to test the ability of the candidate to plan and undertake a whole investigation or problem-solving task. Scoring individual marks in different tasks, or parts of tasks, removes this holistic element, and can result in performances of very different quality leading to the same final assessment total. For this reason, the final unit mark for each candidate will be the highest total mark achieved on any one task. This total mark is obtained by adding together the marks achieved on each strand of the work on that task.

The requirement is for the highest mark from a single piece of work. It is not essential for this to be complete, in the sense of providing evidence across all strands. It may happen that some

candidates achieve their highest total for a piece of work in which evidence for one or more strands is missing; in such cases this total should be chosen as the final assessment total.

Centres may assess the performance of candidates on any occasion when investigative work is taking place throughout the course.

Recording and submitting marks

Skills Assessment Forms will be provided for centres to record marks submitted for moderation. The final mark must be submitted to OCR on form MS1 by 15th May in the year of entry. These forms are produced and dispatched at the relevant time, based on entry information provided by the Centre.

All assessed work which has contributed to candidates' final totals must be available for moderation.

Strand S: Strategy

Practical investigations are likely to arise out of work on most or all of the course modules. Suitable tasks might be suggested to candidates, but they should also have opportunities to modify or extend these, or to suggest questions or tasks to investigate in topic areas they are studying. Candidates can (and should) obtain more credit for tackling somewhat more demanding tasks, and for being involved in devising the question/task, rather than ‘playing safe’ with a given, or routine task, or one involving little skill in the use of equipment.

Whilst candidates should be encouraged to plan an investigation before starting, there is limited value in requiring them to produce a detailed written plan – as their actions should be open to modification as they proceed. Indeed, it is good practice to try taking a few measurements or making a few observations to get a ‘feel’ for the equipment and the system being investigated, before planning a detailed data collection strategy. For that reason, the candidate’s understanding of issues concerning data is better assessed from the final data set they present (see strand C below), rather than from an initial plan.

Assessment of the quality of strand S focuses on –

- the complexity and demand of the task and approach chosen
- the choice of equipment, materials and techniques
- the degree of independence shown in formulating the task and the approach to it.

Aspect of Performance	Strand S Mark			
	2	4	6	8
a complexity and demand of task	Simple measurement or comparison task, based on straightforward use of simple equipment.	Routine task requiring only limited precision or range of data to be collected.	Straightforward task of limited complexity, but requiring good precision or a wide range of data.	Complex task requiring high levels of precision/reliability in the data collected.
b techniques used	Follow a given technique, but with very limited precision or reliability.	Select and use basic equipment to collect a limited amount of data.	Select and use techniques and equipment which are appropriate for the range of data required.	Justify the choice of equipment and technique to achieve data which is precise and reliable.
c autonomy and independence	The task has been set by the teacher and/or is based on specific, task-related structured worksheets.	The task is closely defined by the teacher, but is carried out with little further guidance.	The task is defined by the candidate from a more general brief, then carried out independently.	The topic is reviewed by the candidate to justify a choice of task. The work is completed independently.

Strand C: Collecting Data

Candidates are expected to be able to collect a set of data in a manner which shows understanding of how to ensure (and assess) quality.

The quality of a data set depends on:

- the quality of individual data points, which in turn depends on:
 - how carefully the measurements have been taken, and how accurate the available instruments are (1aS 1.1-2);
 - how much variation or scatter there is in repeated measurements and the steps that have been taken to assess and deal with this (1aS 1.1-4);
 - whether the instruments used, or the way they are used, results in measurements that differ from the 'true' value of the quantity (1aS 1.1-2).
- the extent and design of the set of data points collected, that is:
 - whether enough data points have been collected (1aS 2.1, 2.3, 2.7);
 - whether these cover an adequate range (of cases, or situations, or values of an independent variable) (1aS 2.3);
 - (if a relationship is being explored) whether the design of the data set enables the effect of other variables to be excluded (e.g. (1aS 2.2-3, 2.6-7).

Candidates should use preliminary experiments or other information to confirm that their choices of techniques and range of values to be tested will lead to results of good quality.

The statements are written to refer to primary data that the candidate has collected. Where this is supported by data from secondary sources, the statements should be read as referring to the data 'selected' (as opposed to 'collected'). The mark awarded should be based on all of the data considered as a whole.

Aspect of Performance	Strand C Mark			
	2	4	6	8
a identification and control of interfering factors	Little or no care has been taken to identify or control outside influences.	Identifies some factors which may affect the outcomes and need to be controlled or accounted for.	Identifies the majority of factors which may affect the outcomes and need to be controlled or accounted for.	Reviews factors which might affect the outcomes and describes how they have been controlled or accounted for.
b extent and design of data set	The data is very limited in amount (e.g. isolated individual data points, with no clear pattern), covering only part of the range of relevant cases/ situations, with no checking for reliability.	An adequate amount or range of data is collected, but with little or no checking for reliability.	Data is collected to cover the range of relevant cases/ situations, with regular repeats or checks for reliability.	Values tested are well-chosen across the range, with regular repeats and appropriate handling of any anomalous results. Preliminary tests are used to establish the range.
c quality/ precision of manipulation	Little care evident in use of apparatus. Data generally of low quality.	Use of techniques and apparatus generally satisfactory. Data of variable quality, with some operator error apparent.	Sound techniques in use of apparatus/ equipment. Data of generally good quality.	Consistent precision and skill shown in use of apparatus/ equipment. Where appropriate, checks or preliminary work are included to confirm or adapt the apparatus or techniques to ensure data of high quality.

Strand I: Interpreting Data

Candidates are expected to be able to:

- present or process a set of data in such a manner as to bring out any 'patterns'¹ that are present;
- state conclusions based on these patterns;
- relate their conclusions to scientific theories or understanding;

In the following table, each row represents increasing achievement in a different aspect of performance.

Aspect of Performance	Strand I Mark			
	2	4	6	8
a graphical or numerical processing of data	Display limited numbers of results in tables, charts or graphs, using given axes and scales.	Construct simple charts or graphs to display data in an appropriate way, allowing some errors in scaling or plotting.	Correctly select scales and axes and plot data for a graph, including an appropriate line (normally a line of best fit) or construct complex charts or diagrams (e.g. stacked histograms, species distribution maps).	Additionally, indicate the spread of data (e.g. through scatter-graphs or error bars) and give clear keys for displays involving multiple data-sets.
	Select individual results as a basis for conclusions.	Carry out simple calculations e.g. correct calculation of averages from repeated readings.	Use mathematical comparisons between results to support a conclusion	Use complex processing to reveal patterns in the data e.g. statistical methods, use of inverse relationships, or calculation of gradient of graphs.
b summary of evidence	Note differences between situations/cases, or compare individual results.	Identify trends or general correlations in the data.	Describe formal or statistical relationships within the cases/situations studied.	Review the extent of, or limitations to, formal conclusions in relation to the scatter evident in the data.
c explanations suggested	Link the outcomes to previous experience or 'common sense'.	Relate the conclusion to scientific ideas/explanations.	Justify the conclusion by reference to relevant scientific knowledge and understanding.	Use detailed scientific knowledge to explain all aspects of the given conclusion.

¹ 'Patterns' here means similarities, or differences, or the presence or absence of a relationship (e.g. a correlation between a factor and an outcome, or a trend linking two variables)

Strand E: Evaluation

Candidates are expected to be able to look back at the investigation they have carried out, showing what they have learned from doing it and explaining how they would modify it in the light of this, were they to carry it out again. These suggestions may demonstrate understanding of:

- difficulties in collecting valid and reliable data;
- weaknesses in the design of the data set collected, such as imperfect control of other variables, or the size and matching of samples compared;
- assessing the level of confidence that can be placed in these conclusions.

Aspect of Performance	Strand E Mark			
	2	4	6	8
a evaluation of procedures	Make a relevant comment about how the data was collected and about safety procedures.	Comment on the limitations to accuracy or range of data imposed by the techniques and equipment, used.	Suggest improvements to apparatus or techniques, or alternative ways to collect the data, but without sufficient practical detail.	Describe in detail improvements to the apparatus or techniques, or alternative ways to collect the data, and explain why they would be an improvement.
b reliability of evidence	Make a claim for accuracy or reliability, but without appropriate reference to the data.	Note the presence or absence of results that are beyond the range of experimental error.	Use the general pattern of results or degree of scatter between repeats as a basis for assessing accuracy and reliability.	Consider critically the reliability of the evidence, accounting for any anomalies.
c reliability of conclusion	Relate judgement of the reliability (or otherwise) of the conclusions only to techniques used, not to data collected.	Link confidence in the conclusion to the apparent reliability of the data collected.	Discuss the precision of apparatus and techniques, the range covered and reliability of data to establish a level of confidence in the conclusions	Identify weaknesses in the data and give a detailed explanation of what further data would help to make the conclusions more secure.

Strand P: Presentation

The ability to report clearly and effectively on one's work is essential in order to demonstrate understanding of the Ideas about Science that relate to practical investigations.

Credit is awarded for three aspects of reporting and communicating a practical investigation:

- completeness of the report, with all practical procedures clearly described, all parameters and evidence reported, a full analysis of the evidence, and an evaluation of both procedures and evidence;
- presentation of the report, including layout and effective sequencing, use of illustrations as appropriate and use of graphs and charts to present information;
- correct use of English, including accurate grammar, punctuation and appropriate use of scientific terms.

Aspect of Performance	Strand P Mark			
	2	4	6	8
a description of work planned and carried out	The purpose/context of the investigation is not made clear. Key features of experimental procedures are omitted or unclear.	The purpose of the work is stated. Main features of the work are described, but there is a lack of detail.	There is a clear statement of the question/task and its scope. Practical procedures are clearly described.	All aspects of the task are reviewed. Practical procedures are discussed critically and in detail.
b recording of data	Major experimental parameters are not recorded. Some data may be missing.	Most relevant data is recorded, but where repeats have been used, average values rather than raw data may be recorded.	All raw data, including repeat values, are recorded.	All relevant parameters and raw data including repeat values are recorded to an appropriate degree of accuracy.
	Labelling of tables is inadequate. Most units are absent or incorrect.	Labelling is unclear or incomplete. Some units may be absent or incorrect.	All quantities are identified, but some units may be omitted.	A substantial body of information is correctly recorded to an appropriate level of accuracy in well-organised ways.
	Observations are incomplete or sketchily recorded.	Recording of observations is adequate but lacks detail.	Observations are adequate and clearly recorded.	Observations are thorough and recorded in full detail.
c general quality of communication	Spelling, punctuation and grammar are of generally poor quality. Little or no relevant technical or scientific vocabulary is used.	Use of appropriate vocabulary is limited. Spelling, punctuation and grammar are of very variable quality.	Appropriate scientific vocabulary is used. Spelling, punctuation and grammar are generally sound.	There is full and effective use of relevant scientific terminology. Spelling, punctuation and grammar are almost faultless.

5.3 Regulations for Internally Assessed Work

Supervision and Authentication of work

OCR expects teachers to supervise and guide candidates who are undertaking work that is internally assessed. The degree of teacher guidance will vary according to the kind of work being undertaken. It should be remembered, however, that candidates are required to reach their own judgements and conclusions.

When supervising internally assessed tasks, teachers are expected to:

- offer candidates advice about how best to approach such tasks;
- exercise supervision of work in order to monitor progress and to prevent plagiarism;
- ensure that the work is completed in accordance with the specification requirements and can be assessed in accordance with the specified mark descriptions and procedures.

Skills assessment should, wherever possible, be carried out under supervision. However, it is accepted that some tasks may require candidates to undertake work outside the Centre. Where this is the case, the Centre must ensure that sufficient supervised work takes place to allow the teachers concerned to authenticate each candidate's work with confidence.

Production and Presentation of internally assessed work

Candidates must observe certain procedures in the production of internally assessed work.

- Any copied material must be suitably acknowledged.
- Where work includes secondary data, the original sources must be clearly identified.
- Each candidate's assessed work submitted for moderation should be stapled together at the top left hand corner and have a completed cover sheet as the first page.

Annotation of Candidates' Work

Each piece of assessed work should be annotated to show how the marks have been awarded in relation to the mark descriptions.

The writing of comments on candidates' work provides a means of dialogue and feedback between teacher and candidate and a means of communication between teachers during internal standardisation of marking.

However, the main purpose of annotating candidates' work is to provide a means of communication between teacher and moderator, showing where marks have been awarded and why they have been awarded.

Annotations should be made at appropriate points in the margins of the script of all work submitted for moderation. The annotations should indicate where achievement for a particular skill has been recognised.

It is suggested that the minimum which is necessary is that the 'shorthand' mark descriptions (for example, Ea8) should be written at the point on the script where it is judged that the work has met the mark description.

Moderation

All internally assessed work is marked by the teacher and internally standardised by the Centre. Marks are then submitted to OCR by a specified date, after which moderation takes place in accordance with OCR procedures. The purpose of moderation is to ensure that the standard of the award of marks is the same for each Centre and that each teacher has applied the standards appropriately across the range of candidates within the Centre.

It is the responsibility of the Centre to carry out effective internal standardisation to ensure that similar standards are applied by each teacher involved in the assessment. The Moderator will require a written statement describing how internal standardisation has been carried out within the Centre.

External moderation will be by postal sample selected by the Moderator.

The sample will represent performance across the whole ability range from the Centre. The sample of work which is presented to the Moderator for moderation must show how the marks have been awarded in relation to the mark descriptions.

Separate cover sheets are required for each candidate's work in the sample submitted for moderation.

Minimum Requirements for internally assessed work

If a candidate submits no work for this internally assessed unit, then the candidate should be indicated as being absent from that unit on the mark sheets submitted to OCR. If a candidate completes any work at all for an internally assessed unit, then the work should be assessed according to the criteria and mark descriptions and the appropriate mark awarded, which may be zero.

6 Technical Information

6.1 Making Unit Entries

Please note that centres must be registered with OCR in order to make any entries, including estimated entries. It is recommended that centres apply to OCR to become a registered centre well in advance of making their first entries. Centres should be aware that a minimum of ten candidates for summer examinations is normally required.

Unit Entry Options

Within Units A215, A216, A217 and A218 candidates must be entered for either the Foundation Tier or the Higher Tier option. It is not necessary for candidates to enter at the same tier in every unit. Candidates may, if they wish, attempt papers at both tiers, but not in the same examination session, since the papers will be timetabled simultaneously.

Entry code	Option code	Component to be taken
A215	F	01 Additional Science Unit 1 – modules B4, C4, P4 Foundation
	H	02 Additional Science Unit 1 – modules B4, C4, P4 Higher
A216	F	01 Additional Science Unit 2 – modules B5, C5, P5 Foundation
	H	02 Additional Science Unit 2 – modules B5, C5, P5 Higher
A217	F	01 Additional Science Unit 3 – modules B6, C6, P6 Foundation
	H	02 Additional Science Unit 3 – modules B6, C6, P6 Higher
A218	F	01 Additional Science Unit 4 – Ideas in Context Foundation
	H	02 Additional Science Unit 4 – Ideas in Context Higher
A220	–	01 Additional Science Unit 5 – Practical Investigation

Candidate entries must be made by 21 October for the January session and by 21 February for the June session.

6.2 Making Qualification Entries

Candidates must be entered for certification code **J631** to claim their overall GCSE grade.

If a certification entry is not made, no overall grade can be awarded.

A candidate who has completed all the units required for the qualification may enter for certification either in the same examination session (within a specified period after publication of results) or at a later session.

First certification will be available in June 2008 and every January and June thereafter.

Certification cannot be declined.

6.3 Grading

GCSE results are awarded on the scale A*-G. Units are awarded a* to g. Grades are awarded on certificates. Results for candidates who fail to achieve the minimum grade (G or g) will be recorded as unclassified (U or u).

In modular schemes candidates can take units across several different sessions. They can also re-sit units or choose from optional units available. When working out candidates' overall grades OCR needs to be able to compare performance on the same unit in different sessions when different grade boundaries have been set, and between different units. OCR uses uniform marks to enable this to be done.

A candidate's uniform mark is calculated from the candidate's raw mark. The raw grade boundary marks are converted to the equivalent uniform mark boundary. Marks between grade boundaries are converted on a pro rata basis.

When unit results are issued, the candidate's unit grade and uniform mark are given. The uniform mark is shown out of the maximum uniform mark for the unit e.g. 41/50.

Results for each unit will be published in the form of uniform marks according to the following scales.

	Unit Grade								
	a*	a	b	c	d	e	f	g	u
Units 1, 2, 3 and 4	50-45	44-40	39-35	34-30	29-25	24-20	19-15	14-10	10-0
Unit 5	100-90	89-80	79-70	69-60	59-50	49-50	39-30	29-20	19-0

Higher tier candidates may achieve an "allowed e". Higher tier candidates who miss a grade e will be given a uniform mark in the range f-u but will be graded as 'u'.

Candidates' uniform marks for each module are aggregated and grades for the specification are generated on the following scale.

Qualification Grade								
A*	A	B	C	D	E	F	G	U
300-270	269-240	239-210	209-180	179-150	149-120	119-90	89-60	59-0

The candidate's grade will be determined by this total mark. Thus, the grade awarded will depend in practice upon the extent to which the candidate has met the assessment objectives overall. Shortcomings in some aspects of the assessment may be balanced by better performance in others. Candidates achieving less than the minimum mark for grade G will be unclassified.

6.4 Result Enquiries and Appeals

Under certain circumstances, a centre may wish to query the grade available to one or more candidates or to submit an appeal against an outcome of such an enquiry. Enquiries about unit results must be made immediately following the series in which the relevant unit was taken.

For procedures relating to enquires on results and appeals, centres should consult the OCR Handbook for Centres and the document Enquiries about Results and Appeals – Information and Guidance for Centres produced by the Joint Council. Copies of the most recent editions of these papers can be obtained from OCR.

6.5 Shelf-Life of Units

Individual unit results, prior to certification of the qualification, have a shelf-life limited only by that of the qualification.

6.6 Unit and Qualification Re-sits

Prior to certification, candidates may re-sit any unit once only. *Centres should note that at the time of publication this rule is under review.*

For each unit the better score will be used towards the final overall grade.

Candidates may enter for the full qualifications an unlimited number of times.

6.7 Guided Learning Hours

GCSE Additional Science requires 120 guided learning hours in total.

6.8 Code of Practice/Subject Criteria/Common Criteria Requirements

These specifications comply in all respects with the revised GCSE, GCE, VCE, GNVQ and AEA Code of Practice 2005/6, the subject criteria for GCSE Additional Science and The Statutory Regulation of External Qualifications 2004.

6.9 Arrangements for Candidates with Particular Requirements

For candidates who are unable to complete the full assessment or whose performance may be adversely affected through no fault of their own, teachers should consult the Access Arrangements and Special Consideration Regulations and Guidance Relating to Candidates who are Eligible for Adjustments in Examinations. In such cases advice should be sought from OCR as early as possible during the course.

6.10 Prohibited Qualifications and Classification Code

Every specification is assigned to a national classification code indicating the subject area to which it belongs.

Centres should be aware that candidates who enter for more than one GCSE qualification with the same classification code will have only one grade (the highest) counted for the purpose of the School and College Performance Tables.

The classification code for this specification is 1320.

7 Other Specification Issues

7.1 Overlap with other Qualifications

This specification has been developed alongside GCSE Science A and GCSE Additional Applied Science, GCSE Biology A, GCSE Chemistry A, GCSE Physics A. Aspects of the assessment of skills are common across some of these qualifications.

7.2 Progression from these Qualifications

GCSE qualifications are general qualifications which enable candidates to progress either directly to employment, or to proceed to further qualifications.

Many candidates who enter employment with one or more GCSEs would undertake training or further part-time study with the support of their employers.

Progression to further study from GCSE will depend upon the number and nature of the grades achieved. Broadly, candidates who are awarded mainly grades G to D at GCSE could either strengthen their base through further study of qualifications at Level 1 within the National Qualifications Framework or could proceed to Level 2. Candidates who are awarded mainly grades C to A* at GCSE would be well prepared to broaden their base through further study of qualifications at Level 2 or to proceed to appropriate qualifications at Level 3 within the National Qualifications Framework. Candidates intending to proceed to qualifications in the sciences at Advanced Level (Level 3 in the National Qualifications Framework) should have completed courses in both GCSE Science and GCSE Additional Science or GCSE Additional Applied Science.

7.3 ICT

In order to move on to more advanced study of science, candidates need to be confident and effective users of ICT. This specification provides candidates with a wide range of appropriate opportunities to use ICT in order to further their study of science.

Opportunities for ICT include:

- using of videos clips to show provide the context for topics studied and to illustrate the practical importance of the scientific ideas.
- gathering information from the Internet and CD-ROMs;
- gathering data using sensors linked to data-loggers or directly to computers;
- using spreadsheets and other software to process data;
- using animations and simulations to visualise scientific ideas;
- using modelling software to explore theories;
- using software to present ideas and information on paper and on screen.

Particular opportunities for the use of ICT appear in the introductions to each of the modules.

7.4 Citizenship

Since September 2002, the National Curriculum for England at Key Stage 4 has included a mandatory programme of study for Citizenship.

Core science is designed as a science education for future citizens which not only covers aspects of the Citizenship programme of study but also extends beyond that programme by dealing with important aspects of science which all people encounter in their everyday lives.

Citizenship Programme of Study	Opportunities for Teaching the Issues during the Course
--------------------------------	---

Section 1: Knowledge and understanding about becoming informed citizens

How the economy functions, including the role of business and financial services

C5: The role of manufacturing industry in adding value by extracting metals from their ores.

P5: The basis for charging customers for electricity supplies.

C6: The scale and importance of the chemical industry

The media's role in society, including the internet, in providing information and affecting opinion

B6: Media reporting of the effects of Ecstasy contrasted with the scientific evidence.

The rights and responsibilities of consumers, employers and employees

C6: The responsibility of the chemical industry to minimise damage to people and the environment while producing products that are effective and safe.

The issues and challenges of global interdependence and responsibility, including sustainable development and Local Agenda 21

C5: Insight into the chemical nature of the natural environment needed for an understanding of issues of sustainability including the use of manufactured fertilisers.

7.5 Key Skills

These specifications provide opportunities for the development of the Key Skills of Communication, Application of Number, Information Technology, Working with Others, Improving Own Learning and Performance and Problem Solving at Levels 1 and/or 2. However, the extent to which this evidence fulfils the Key Skills criteria at these levels will be totally dependent on the style of teaching and learning adopted for each unit.

The following table indicates where opportunities may exist for at least some coverage of the various Key Skills criteria at Levels 1 and/or 2 for each unit.

Level	Communication	Application of Number	IT	Working with Others	Improving Own Learning and Performance	Problem Solving
1	✓	✓	✓	✓	✓	✓
2	✓	✓	✓	✓	✓	✓

7.6 Spiritual, Moral, Ethical, Social, Legislative, Economic and Cultural Issues

A number of the scientific ideas which feature in this specification have a significant cultural influence on how people think about themselves and their environment. Also in this specification, candidates gain more insight into the reliability and significance of scientific data.

Issue	Opportunities for Teaching the Issues during the Course
The commitment of scientists to publish their findings and subject their ideas to testing by others.	Investigation: reviewing the strategy and procedures.
The range of factors which have to be considered when weighing the costs and benefits of scientific activity.	C6: Evaluating the costs and benefits associated with chemical manufacturing.
Scientific explanations which give insight into human nature	B4: Insight into the ability of human beings to survive under extreme conditions. B6: The study of higher functions of the human brain – intelligence, memory, language and consciousness.
Scientific explanations which give insight into everyday experiences	P4: Theories of forces and motion and their implications for human safety in motor vehicles and other forms of transport. P5: Models for the behaviour of electric circuits and their practical importance for the generation of electricity. P6: The importance of the electromagnetic spectrum in modern forms of communication including digital methods.
Scientific explanations which give insight into the local and global environment	C5: Insight into the chemical nature of natural changes in the lithosphere, hydrosphere, atmosphere and biosphere.

7.7 Sustainable Development, Health and Safety Considerations and European Developments

OCR has taken account of the 1988 Resolution of the Council of the European Community and the Report Environmental Responsibility: An Agenda for Further and Higher Education, 1993 in preparing this specification and associated specimen assessments.

Issue	Opportunities for Teaching the Issues during the Course
-------	---

Environmental issues

Managing wastes from manufacturing industry	C6: The by-products and waste products of chemical manufacturing and what can be done to mitigate potential harmful effects.
Food and agriculture	C5: The scale of the impact of the use of manufactured fertilisers on the nitrogen cycle.
Use and disposal of materials	C5: Recycling metals and other ways of reducing the quantity of waste products from mineral processing and the extraction of metals from their ores.

Health and Safety issues

Safe practice in the laboratory	Investigation: designing a strategy
Health and disease	B4: Scientific basis for heat stroke, hypothermia, dehydration and the effect of drugs on the body. B6: The beneficial and harmful effects of drugs which affect the nervous system.
Safety in motor vehicles and other forms of transport	P4: Theories of forces and motion and their implications for human safety in motor vehicles and other forms of transport.

OCR has taken account of the 1988 Resolution of the Council of the European Community in preparing this specification and associated specimen assessments. European examples should be used where appropriate in the delivery of the subject content.

Although this specification does not make specific reference to the European Dimension it may be drawn into the course of study in a number of ways. The table below provides some appropriate opportunities.

Issue	Opportunities for Teaching the Issues during the Course
-------	---

The importance of the science-based industry to European economies	C6 The economic importance of the chemical industry in the UK and other countries.
Environmental issues which extend over a larger area than the UK	C5: Impact of European agriculture policy on the scale and methods of different forms of agriculture. C6: The European wide approach to green chemistry and the quest to develop more efficient and less polluting processes.

7.8 Avoidance of Bias

OCR has taken great care in preparation of these specifications and assessment materials to avoid bias of any kind.

7.9 Language

These specifications and associated assessment materials are in English only.

7.10 Support and Resources

The University of York Science Education Group (UYSEG) and the Nuffield Curriculum Centre have produced resources specifically to support this specification. The resources will comprise:

- candidates' texts;
- candidates' work books;
- teacher guide with suggested schemes of work and candidate activity sheets (in customizable format);
- technician guide;
- ICT resources (for example, animations, video clips, models and simulations);
- assessment materials;
- a website for teachers and candidates.

The resources are published by Oxford University Press. Further information is available from:

Customer Services: Telephone: 01536 741068
Fax: 01536 454579
email: schools.orders@oup.com

Support is also available from the OCR GCSE science website www.gcse-science.com where centres should register their intention to offer this qualification. Registering on this site provides access to a teachers' forum and local support networks.

Appendix A: Grade Descriptions

Grade F

Candidates demonstrate a limited knowledge and understanding of science content and how science works. They use a limited range of the concepts, techniques and facts from the specification, and demonstrate basic communication and numerical skills, with some limited use of technical terms and techniques.

They show some awareness of how scientific information is collected and that science can explain many phenomena.

They use and apply their knowledge and understanding of simple principles and concepts in some specific contexts. With help they plan a scientific task, such as a practical procedure, testing an idea, answering a question, or solving a problem, using a limited range of information in an uncritical manner. They are aware that decisions have to be made about uses of science and technology and, in simple situations familiar to them, identify some of those responsible for the decisions. They describe some benefits and drawbacks of scientific developments with which they are familiar and issues related to these.

They follow simple instructions for carrying out a practical task and work safely as they do so.

Candidates identify simple patterns in data they gather from first-hand and secondary sources. They present evidence as simple tables, charts and graphs, and draw simple conclusions consistent with the evidence they have collected.

Grade C

Candidates demonstrate a good overall knowledge and understanding of science content and how science works, and of the concepts, techniques, and facts across most of the specification. They demonstrate knowledge of technical vocabulary and techniques, and use these appropriately. They demonstrate communication and numerical skills appropriate to most situations.

They demonstrate an awareness of how scientific evidence is collected and are aware that scientific knowledge and theories can be changed by new evidence.

Candidates use and apply scientific knowledge and understanding in some general situations. They use this knowledge, together with information from other sources, to help plan a scientific task, such as a practical procedure, testing an idea, answering a question, or solving a problem.

They describe how, and why, decisions about uses of science are made in some familiar contexts. They demonstrate good understanding of the benefits and risks of scientific advances, and identify ethical issues related to these.

They carry out practical tasks safely and competently, using equipment appropriately and making relevant observations, appropriate to the task. They use appropriate methods for collecting first-hand and secondary data, interpret the data appropriately, and undertake some evaluation of their methods.

Candidates present data in ways appropriate to the context. They draw conclusions consistent with the evidence they have collected and evaluate how strongly their evidence supports these conclusions.

Grade A

Candidates demonstrate a detailed knowledge and understanding of science content and how science works, encompassing the principal concepts, techniques, and facts across all areas of the specification. They use technical vocabulary and techniques with fluency, clearly demonstrating communication and numerical skills appropriate to a range of situations.

They demonstrate a good understanding of the relationships between data, evidence and scientific explanations and theories. They are aware of areas of uncertainty in scientific knowledge and explain how scientific theories can be changed by new evidence.

Candidates use and apply their knowledge and understanding in a range of tasks and situations. They use this knowledge, together with information from other sources, effectively in planning a scientific task, such as a practical procedure, testing an idea, answering a question, or solving a problem.

Candidates describe how, and why, decisions about uses of science are made in contexts familiar to them, and apply this knowledge to unfamiliar situations. They demonstrate good understanding of the benefits and risks of scientific advances, and identify ethical issues related to these.

They choose appropriate methods for collecting first-hand and secondary data, interpret and question data skilfully, and evaluate the methods they use. They carry out a range of practical tasks safely and skilfully, selecting and using equipment appropriately to make relevant and precise observations.

Candidates select a method of presenting data appropriate to the task. They draw and justify conclusions consistent with the evidence they have collected and suggest improvements to the methods used that would enable them to collect more valid and reliable evidence.

Appendix B: Requirements Relating to Mathematics

During the course of study for this specification, many opportunities will arise for quantitative work, including appropriate calculations. The mathematical requirements which form part of the specification are listed below. Items in the first table may be examined in written papers covering both Tiers. Items in the second table may be examined only in written papers covering the Higher Tier.

Both Tiers

add, subtract, multiply and divide whole numbers
recognise and use expressions in decimal form
make approximations and estimates to obtain reasonable answers
use simple formulae expressed in words
understand and use averages
read, interpret, and draw simple inferences from tables and statistical diagrams
find fractions or percentages of quantities
construct and interpret pie-charts
calculate with fractions, decimals, percentage or ratio
solve simple equations
substitute numbers in simple equations
interpret and use graphs
plot graphs from data provided, given the axes and scales
choose by simple inspection and then draw the best smooth curve through a set of points on a graph

Higher Tier only

recognise and use expressions in standard form
manipulate equations
select appropriate axes and scales for graph plotting
determine the intercept of a linear graph
understand and use inverse proportion
calculate the gradient of a graph

Appendix C: Physical Quantities and Units

It is expected that candidates will show an understanding of the physical quantities and corresponding SI units listed below and will be able to use them in quantitative work and calculations. Whenever they are required for such questions, units will be provided and, where necessary, explained.

Fundamental physical quantities

Fundamental Physical Quantities	
Physical quantity	Unit(s)
length	metre (m); kilometre (km); centimetre (cm); millimetre (mm)
mass	kilogram (kg); gram (g); milligram (mg)
time	second (s); millisecond (ms)
temperature	degree Celsius ($^{\circ}\text{C}$); kelvin (K)
current	ampere (A); milliampere (mA)

Derived Quantities and Units	
Physical quantity	Unit(s)
area	cm^2 ; m^2
volume	cm^3 ; dm^3 ; m^3 ; litre (l); millilitre (ml)
density	kg/m^3 ; g/cm^3
force	newton (N)
speed, velocity	m/s; km/h
energy	joule (J) ; kilojoule (kJ); megajoule (MJ)
momentum	kg m/s
power	watt (W); kilowatt (kW); megawatt (MW)
frequency	hertz (Hz); kilohertz (kHz)
gravitational field strength	N/kg

Appendix D: Health and Safety

In UK law, health and safety is the responsibility of the employer. For most centres entering candidates for GCSE examinations this is likely to be the Local Education Authority or the Governing Body. Teachers have a duty to co-operate with their employer on health and safety matters. Various regulations, but especially the COSHH Regulations 1996 and the Management of Health and Safety at Work Regulations 1992, require that before any activity involving a hazardous procedure or harmful microorganisms is carried out, or hazardous chemicals are used or made, the employer must provide a risk assessment.

A useful summary of the requirements for risk assessment in school or college science can be found in Chapter 4 of Safety in Science Education. For members, the CLEAPSS guide, Managing Risk Assessment in Science offers detailed advice.

Most education employers have adopted a range of nationally available publications as the basis for their Model Risk Assessments. Those commonly used include:

- Safety in Science Education, DfEE, 1996, HMSO, ISBN 0 11 270915 X;
- Topics in Safety 3rd edition, 2001, ASE ISBN 0 86357 316 9;
- Safeguards in the School Laboratory, 10th edition, 1996, ASE ISBN 0 86357 250 2;
- Hazcards, 1995 with 2004 updates, CLEAPSS School Science Service*;
- CLEAPSS Laboratory Handbook, 1997 with 2004 update, CLEAPSS School Science Service*;
- CLEAPSS Shorter Handbook (CLEAPSS 2000) CLEAPSS School Science Service*;
- Hazardous Chemicals, A manual for Science Education, (SSERC, 1997) ISBN 0 9531776 0 2.

*Note that CLEAPSS publications are only available to members or associates.

Where an employer has adopted these or other publications as the basis of their model risk assessments, an individual Centre then has to review them, to see if there is a need to modify or adapt them in some way to suit the particular conditions of the establishment. Such adaptations might include a reduced scale of working, deciding that the fume cupboard provision was inadequate or the skills of the candidates were insufficient to attempt particular activities safely.

The significant findings of such risk assessment should then be recorded, for example on schemes of work, published teachers guides, work sheets, etc.

There is no specific legal requirement that detailed risk assessment forms should be completed, although a few employers require this.

When candidates are planning their own investigative work the teacher has a duty to check the plans before the practical work starts and to monitor the activity as it proceeds.

Appendix E: Explanation of Terms Used in Module Content

All the Ideas-about-Science are expressed in terms of what the candidates know, understand or can do, and are prefixed by 'Candidates should be able to...' which is followed by statement containing one or more 'command' words.

This appendix, which is not intended to be exhaustive or prescriptive, provides some guidance about the meanings of these command words.

It must be stressed that the meaning of a term depends on the context in which it is set, and consequently it is not possible to provide precise definitions of these words which can be rigidly applied in all circumstances. Nevertheless, it is hoped that this general guidance will be of use in helping to interpret both the specification content and the assessment of this content in written papers.

Command words associated with scientific knowledge and understanding (AO1)

Candidates are expected to remember the facts, concepts, laws and principles which they have been taught. Command words in this category include Learning Outcomes beginning:

recall..., ...state...; ...recognise...; ...name...; ...draw...; ...test for...; ...appreciate... ; describe...

The words used on examination papers in connection with the assessment of these Learning Outcomes may include:

Describe...; List...; Give...; Name...; Draw...; Write...; What?...; How?...; What is meant by..?

e.g. 'What is meant by the term 'catalyst' ?'

'Name parts A, B and C on the diagram.'

Command words associated with interpretation, evaluation, calculation and communication (AO2)

The command words include:

...relate...; ...interpret...; ...carry out ...; ...deduce...; ..explain...; ...evaluate...;
...predict...; ...use...; ...discuss...; ...construct...; ...suggest...; ...calculate...;
...demonstrate...;

The use of these words involves the ability to recall the appropriate material from the specification content and to apply this knowledge and understanding.











Questions in this category may include the command words listed above together with Why...? Complete... Work out... How would you know that...? Suggest...

e.g. 'Use the graph to calculate the concentration of the acid.'

'Explain why it is important for these materials to be recycled.'

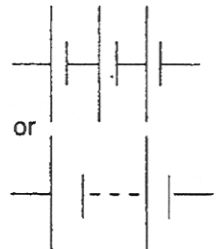
'Suggest two reasons why some people are concerned about the use of these artificial flavours in foods.'

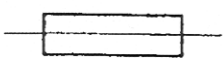
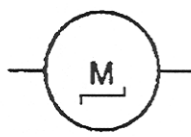
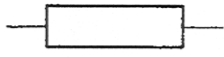
Appendix F: Electrical Symbols

junction of conductors		ammeter	
switch		voltmeter	
primary or secondary cell		indicator or light source	
battery of cells	or 		
power supply			
fuse		motor	
fixed resistor		generator	
variable resistor	